



# W7AE Owner's Manual





## An Introduction

Thank you for purchasing a JL Audio W7AE subwoofer driver. The W7AE embodies JL Audio's commitment to pushing the envelope of speaker technology. Each W7AE model has been meticulously engineered to reproduce sub-bass with extreme fidelity at any volume level, provided it is installed and tuned properly. Please review the information in this document carefully to maximize your enjoyment of the W7AE's capabilities.

Two enclosure recommendations are listed for each model, one sealed and one ported. In most cases, the sealed enclosure design will give you the best overall sound quality and take up the least space in your vehicle. The ported enclosure design will deliver additional output over the sealed enclosure (about 3 - 4 dB more) and will also maintain excellent sound quality, but it will require significantly more space to install. The recommended ported enclosure is not designed for peaky "competition SPL" performance, but rather for music listening. It will be very loud and sound extremely good when set up properly.

Please note that W7AE's rarely require any equalization to produce smooth frequency response. They also do not generally benefit from excessively low crossover points. We recommend that you use crossover points at or above 80 Hz in most cases. This will ensure that you get maximum benefits from the W7's low-frequency output capabilities, while simultaneously reducing the burden on your main speakers. This helps to reduce distortion and improve overall fidelity.

For optimum sub-bass performance, the amplifier input sensitivity **must** be adjusted to avoid excessive distortion (clipping) of the amplifier output. Overly high input sensitivity settings result in no additional clean output but will result in poor sound quality and reduced speaker reliability. With W7AE subwoofers, a clipped amplifier output may manifest itself audibly as a low-level "mechanical" sound coming from the speakers. Proper input sensitivity setting will avoid this problem.

### RECOMMENDED CONTINUOUS (RMS) POWER RANGE FOR ONE SUBWOOFER DRIVER:

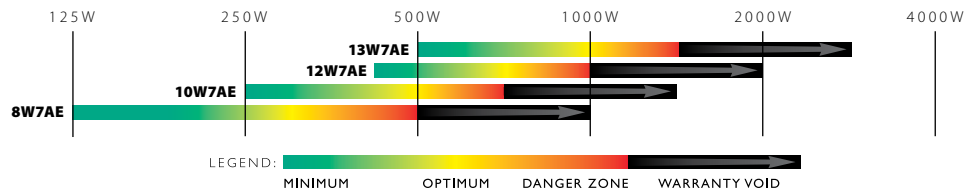

#### GREEN (MINIMUM):

From a reliability standpoint, this zone represents a very comfortable operating power range for each driver. This level of power will not stress the woofer but will not extract all of its performance potential, either.

Use of less than the minimum power level will not damage the woofer, but may result in unsatisfactory performance.

#### YELLOW (OPTIMUM):

This zone represents the best balance between long-term reliability, high output and low distortion performance. In this zone, you will be taking full advantage of the woofer's optimum, low-distortion performance range without undue risk of failure.

#### RED (MAXIMUM):

In this zone, low-distortion output and long-term reliability will be compromised (especially by an aggressive user). Slightly more SPL will be gained by pushing the power into this zone, but typically not more than 2dB, compared to the yellow zone. The closer you are to the black zone, the higher the likelihood of driver failure. Operate with caution.

#### BLACK (WARRANTY VOID):

We do not recommend operating woofers at this level of power. In this zone, there is a very high probability that the driver will fail due to excessive heat and/or mechanical stress.

**Subwoofer drivers operated at these levels of power are NOT covered under warranty.**

When designing systems with W7AE drivers, it is very important to achieve a good power match between the subwoofer amplifier and the subwoofer driver's capabilities. The power levels listed in the above chart represent continuous (RMS) amplifier power per woofer and assume that the user will regularly make full use of that power **without drastically overdriving (clipping) the amplifier(s)**. Make sure you factor system impedance and the total number of subwoofers into your calculations. Adhering to these power recommendations will result in systems that are both reliable and enjoyable.



## W7AE Subwoofer Drivers: Tight.

The ultimate no-compromise subwoofer for those seeking extreme output and sublime sound quality.

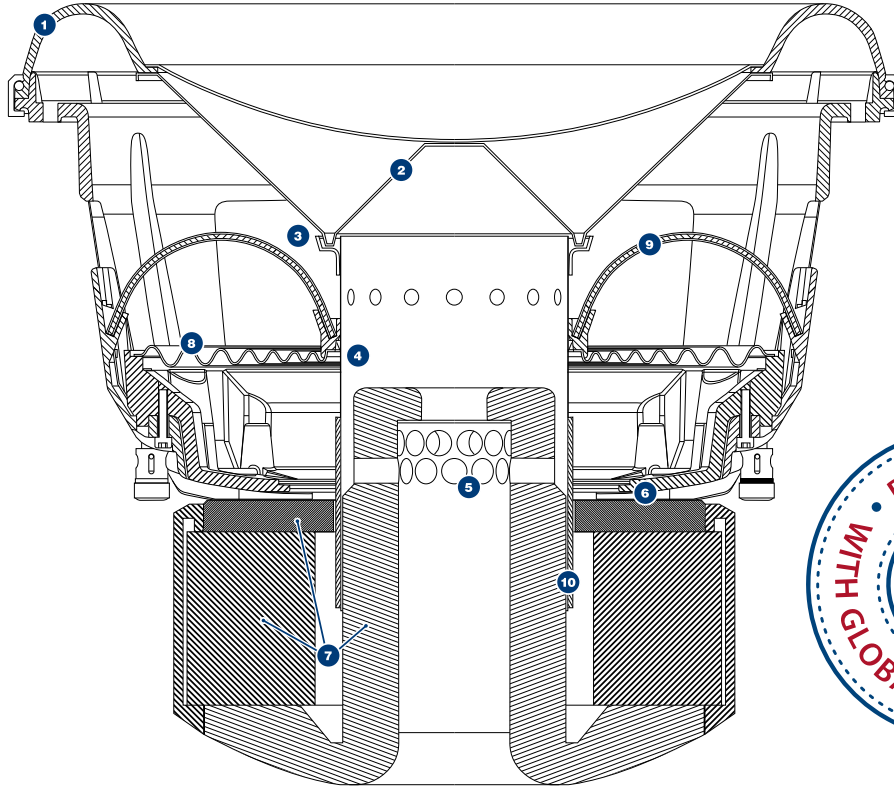

### 1 - OverRoll™ Surround

By utilizing space wasted in conventional speakers, this ground-breaking innovation controls the W7AE's massive excursion without sacrificing precious cone area.

### 2 - W-Cone™

The W-Cone™ is a unit-body cone assembly that delivers astonishing cone stiffness with minimal mass. The shape also provides incredible torsional rigidity, which is critical to maintaining voice coil alignment at the suspension limits.

### 3 - Floating-Cone™ Attach Method

Ensures proper surround geometry in the assembled speaker for better excursion control and dynamic voice coil alignment. A small detail that means a lot when you're pumping the cone to the excursion extremes the W7AE is capable of.

### 4 - Plateau-Reinforced Spider Attachment

A derivative of JL Audio's famous VRC technology, this bulletproof suspension attachment relieves stress from the spider material at high-excursions for enhanced reliability.

### 5 - Radially Cross-Drilled Pole Piece

This innovative venting system greatly enhances thermal dissipation and power handling by directing air flow onto the voice coil former, working in conjunction with technology #6.

### 6 - Elevated Frame Cooling

The elevated frame design of the W7AE delivers cool air through slots directly above the top-plate to the voice coil of the speaker. This not only enhances power handling, but also improves sound quality by minimizing dynamic parameter shifts and power compression.

### 7 - Highly Linear, DMA-Optimized Motor System

DMA is JL Audio's proprietary Dynamic Motor Analysis system and is aimed at improving dynamic motor behavior. As a result of DMA optimization, W7AE motors remain linear in motor force over an extreme range of excursion and also maintain a highly stable fixed magnetic field in the gap over a wide power range. This leads to vastly reduced distortion and faithfully reproduced transients... or put simply: tight, clean, articulate bass.

### 8 - Huge Diameter, Progressive-Roll Spider

Arrived at after intense computer analysis and optimization, the W7AE spiders provide precise control and motor/voice coil alignment without prematurely limiting excursion.

### 9 - Co-Extruded Double Lead-Wires

The extruded casing and carefully engineered attachments ensure controlled lead-wire behavior under the most extreme excursion demands. Two conductors are used per connection for ample current carrying capability.

### 10 - Ultra-long Voice Coil

To allow extreme linear excursion, phenomenal power handling and control, control, control.

#### WARNING:

Prolonged exposure to high sound pressure levels can lead to permanent hearing loss. W7AE subwoofers are capable of reproducing sound at extremely high sound pressure levels. Please exercise restraint in the operation of your system in order to preserve your hearing and your long-term enjoyment of this product's sound quality capabilities.



## W7AE Subwoofer Drivers: Mounting Guide.

Please review the mounting procedures thoroughly before attempting to remove the speaker from its shipping baffle. The W7AE mounts like no other speaker and care must be taken to follow these instructions precisely.



1

### Step 1: Your Tools

When you remove the W7AE from its shipping carton, it is attached to an MDF baffle board. Make sure you keep this baffle board and all the packing material in the unlikely event that the W7AE ever needs to be shipped back to JL Audio for service.

Two tools are required to install a W7AE: a large flat blade screwdriver and an electric screwdriver with a #2 Phillips-head bit.

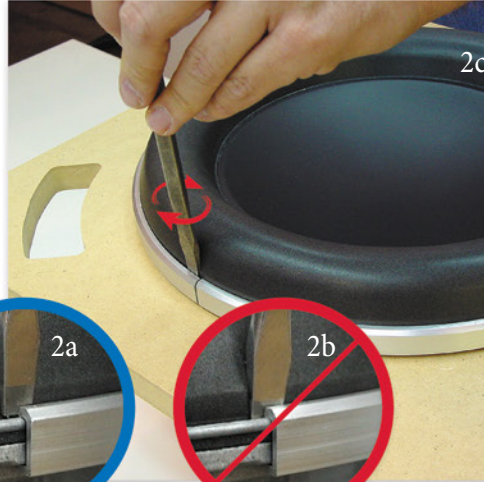

2c



2a

Correct

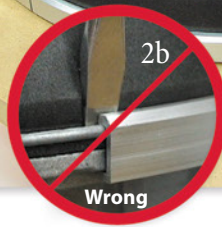

2b

Wrong

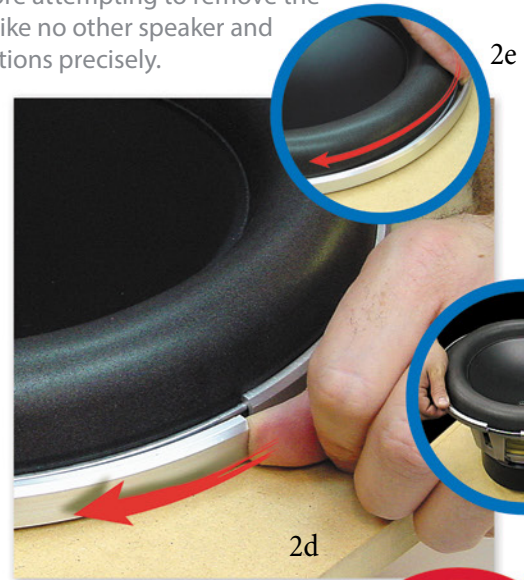

2d



2e



2f



Wrong

2g

### Step 2: Remove Clamp-Ring

Gently insert the tip of the large flat-head screwdriver between the shiny aluminum clamp-ring and the foam surround (picture 2a). Be careful not to push the screwdriver too far down or it will wedge behind the hidden O-Ring (picture 2b). Gently twist the screwdriver to "pop" the clamp-ring off of the O-Ring and frame (picture 2c). This should require little effort... if you are encountering high resistance, pull the screwdriver up a bit to make sure it is not wedged behind the O-Ring. Once you have released the tip of the clamp-ring, a gentle push with your thumb in the direction of the speaker circumference (picture 2d) will separate the clamp-ring fully (picture 2f). Do not pull up on the ring until it is completely removed (picture 2g).



3a

### Step 3: Remove O-Ring

Once the clamp-ring is removed, the steel O-Ring is exposed. Gently lift this O-Ring up and off the speaker with your fingertips and set it aside.



3b



4a

4b



Correct

4c



Wrong

4d



Wrong

4e

### Step 4: Remove Screws

Once the O-Ring is out of the way, the surround is completely free of the speaker frame (no glue is used to secure it). Lift the surround up and fold it back inside the speaker frame (picture 4a). This exposes the mounting screws (picture 4b). The surround should be folded back and in towards the center of the speaker (picture 4c). Do not pull it up (picture 4d) or invert it (picture 4e). While holding the surround back with two fingers as shown, back the first screw out using your electric screwdriver (picture 4f, 4g). Repeat this process eleven more times (there are twelve screws on a W7AE) until you have separated the speaker from the shipping baffle-board. Before you panic, be aware that the surround and cone materials are rugged and will not be damaged if you follow the procedures shown. Only careless acts like picking the speaker up by the surround or creasing it by force will cause permanent damage.

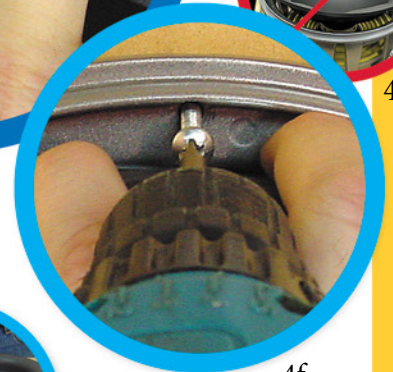

4f



4g

### Step 5: Ready to Install

You are now ready to install the W7AE into its enclosure. The parts are shown below.

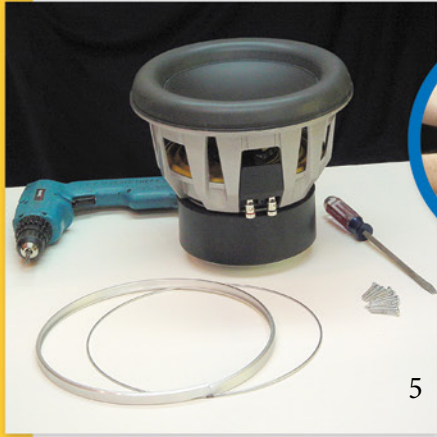

5



6a



6b



7a



7b



7c



8a

### Step 8: Attach O-Ring

Next, take the steel O-Ring that you removed in step 3, and place it over the outside of the surround. Push it down evenly (do **not** seat one side first) to make sure it seats the lower lip of the surround down to the frame (pictures 8a, 8b).



8b



9a

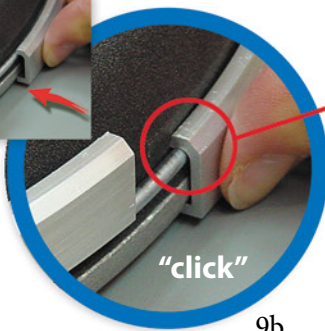

"click"

9b

**IMPORTANT** Be sure that the beveled edge of the clamp-ring is "pointing" towards the front of the speaker. The clamp-ring is only designed to work in this orientation.



9c



9d

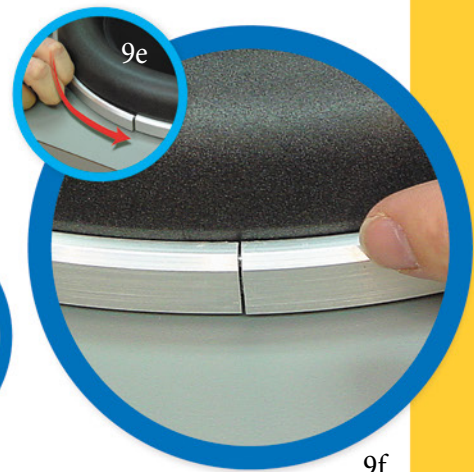

9e

9f

### Step 9: Attach Clamp-Ring

Place the seam of the clamp-ring where it will be least visible in the installation (usually at the bottom of the speaker). Start one end of the clamp-ring by pressing it in firmly (pictures 9a, 9b). Then work your way around from that point around the speaker, pushing the clamp-ring inward and in the direction of the circumference of the frame (pictures 9c, 9d). If you have achieved a tight fit all around, the seam will be small when you reach the starting point again (pictures 9e, 9f). Check the entire circumference for a tight fit just to be sure.

That's it!  
You've just installed a W7AE!



# 8W7AE-3

**Free Air Resonance (Fs):** 35.2 Hz  
**Electrical "Q" (Qes):** 0.654  
**Mechanical "Q" (Qms):** 9.50  
**Total Speaker "Q" (Qts):** 0.612  
**Equivalent Compliance (Vas):** 0.61 cu. ft. (17.4 ltrs)  
**One-Way, Linear Excursion (Xmax)\*:** 0.75 in. (19 mm)  
**Thermal Power Handling (Pt):** 500 Watts Continuous  
**Reference Efficiency (no):** 0.112 %  
**Efficiency (SPL @ 1W/1m):** 82.7 dB  
**DC Resistance (Re):** 2.78Ω  
**Effective Piston Area (Sd):** 38.0 sq. in. (0.0245 sq. m)  
**Nominal Impedance (Znom):** 3Ω

\* Xmax specifications are derived via one-way voice coil overhang method with no correction factors applied.



RECOMMENDED CONTINUOUS (RMS) POWER RANGE FOR ONE SUBWOOFER DRIVER:

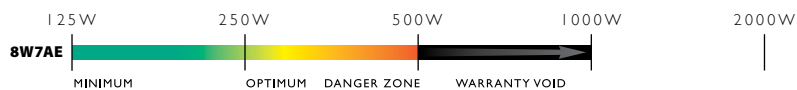



## 8W7AE Subwoofer: Driver & Enclosure Specifications

**Grille Clearance:** 2.3125 in. (25 mm) from the bottom of the mounting flange to the lowest inside surface of the grille.

**Displacement:** 0.06 cu. ft. (1.7 ltrs)

**Net Weight:** 17 lbs. (7.8 kg)

**Mounting Hardware:** Twelve #8 x 1.00" long clear, zinc-plated steel Phillips pan-head sheet metal screws (included) **or** twelve #8-32 long steel Phillips pan-head machine screws with #8-32 T-Nuts, each at least 1/2-inch (12.5 mm) longer than the thickness of the mounting baffle (not included).

**Unpacking/Mounting:** Please refer to the "W7 Installation: Mounting System" sheet for detailed, step-by-step instructions.

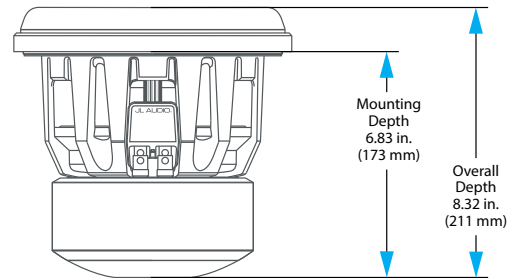
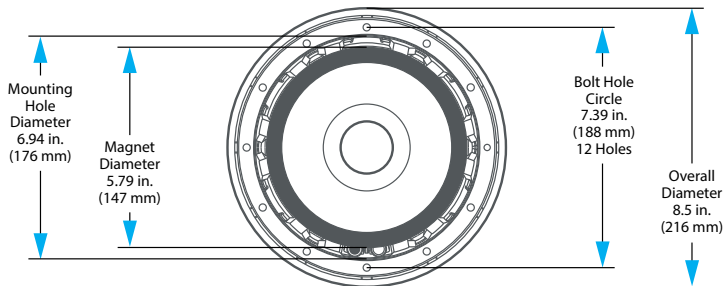

Net volumes given below do not include the air volume displaced by the speaker (Driver Displacement). This value must be added to the net volume along with the displacement of any braces and/or ports (if applicable) to arrive at a gross internal volume. Air inside a port is not part of the effective net volume. Calculate ports as solid, not hollow objects.

The dimensions given for the enclosure examples below take all applicable displacements into consideration.

### SAFETY NOTICE!

It is absolutely essential that the completed subwoofer enclosure is mounted firmly to the vehicle with heavy steel bolts (1/2 inch diameter) and large steel washers on both sides of the bolts. This will reduce the likelihood of occupant injury in the event of a collision or sudden deceleration.

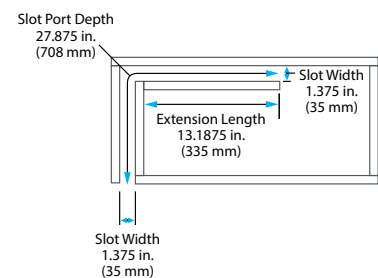
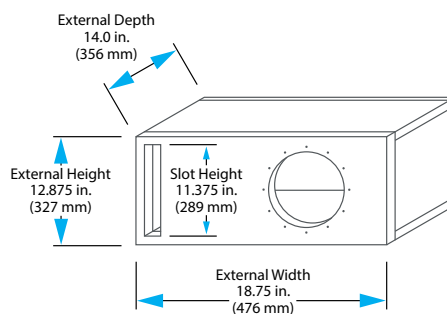
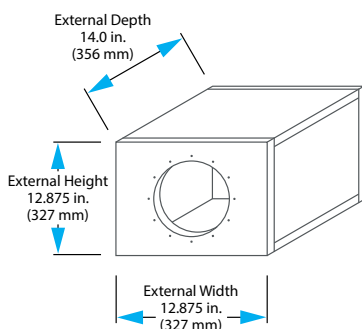

### SEALED ENCLOSURE:

**Recommended Net Volume:** 0.875 cu. ft. (24.8 ltrs.)

**Fc:** 45.9 Hz **F3:** 41.3 Hz **Qtc:** 0.798

**Front Baffle Thickness:** 0.75 in. (19 mm)

**Wall Thickness:** 0.75 in. (19 mm)

### PORTED ENCLOSURE:

**Recommended Net Volume:** 1.0 cu. ft. (28.3 ltrs.)

**Recommended Port Tuning:** 36.8 Hz

**Port Type:** "Slot" ports are recommended. See information above.

The port recommendations listed above are derived through actual tests and measurements (not computer simulations).

**Front Baffle Thickness:** 0.75 in. (19 mm)

**Wall Thickness:** 0.75 in. (19 mm)



# 10W7AE-3

- Free Air Resonance (Fs):** 30.6 Hz
- Electrical "Q" (Qes):** 0.578
- Mechanical "Q" (Qms):** 7.647
- Total Speaker "Q" (Qts):** 0.537
- Equivalent Compliance (Vas):** 1.28 cu. ft. (36.1 ltrs)
- One-Way, Linear Excursion (Xmax)\*:** 0.9 in. (23 mm)
- Thermal Power Handling (Pt):** 750 Watts Continuous
- Reference Efficiency (no):** 0.171 %
- Efficiency (SPL @ 1W/1m):** 84.3 dB
- DC Resistance (Re):** 2.75Ω
- Effective Piston Area (Sd):** 59.8 sq. in. (0.0386 sq. m)
- Nominal Impedance (Znom):** 3Ω

\* Xmax specifications are derived via one-way voice coil overhang method with no correction factors applied.



RECOMMENDED CONTINUOUS (RMS) POWER RANGE FOR ONE SUBWOOFER DRIVER:





## 10W7AE Subwoofer: Driver & Enclosure Specifications

**Grille Clearance:** 2.25 in. (57 mm) from the bottom of the mounting flange to the lowest inside surface of the grille.

**Displacement:** 0.09 cu. ft. (2.5 ltrs)

**Net Weight:** 30 lbs. (13.6 kg)

**Mounting Hardware:** Twelve #10 x 1.75" long clear, zinc-plated steel Phillips pan-head sheet metal screws (included) **or** twelve #10-32 long steel Phillips pan-head machine screws with #10-32 T-Nuts, each at least 1/2-inch (12.5 mm) longer than the thickness of the mounting baffle (not included).

**Unpacking/Mounting:** Please refer to the "How to: Mount a W7AE Subwoofer" on pages 4 & 5 for detailed, step-by-step instructions.

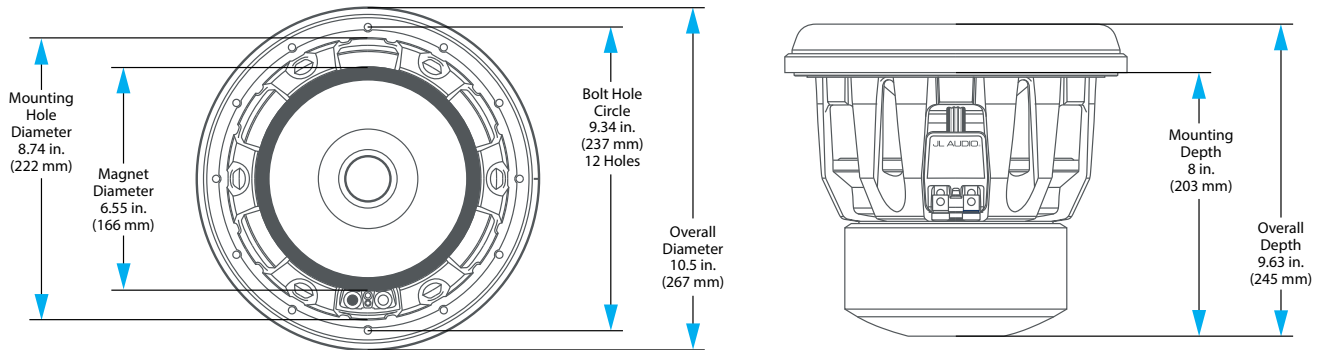

Net volumes given below do not include the air volume displaced by the speaker (Driver Displacement). This value must be added to the net volume along with the displacement of any braces and/or ports (if applicable) to arrive at a gross internal volume. Air inside a port is not part of the effective net volume. Calculate ports as solid, not hollow objects.

The dimensions given for the enclosure examples below take all applicable displacements into consideration.

### SAFETY NOTICE!

It is absolutely essential that the completed subwoofer enclosure is mounted firmly to the vehicle with heavy steel bolts (1/2 inch diameter) and large steel washers on both sides of the bolts. This will reduce the likelihood of occupant injury in the event of a collision or sudden deceleration.

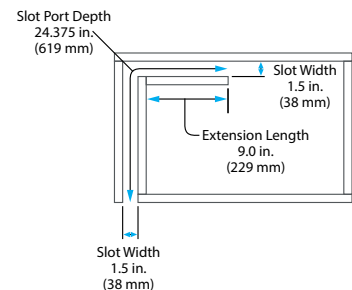
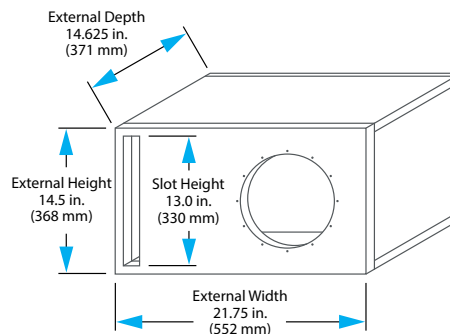
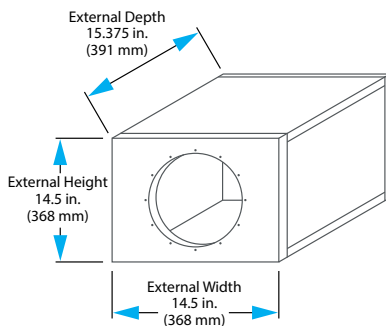

### SEALED ENCLOSURE:

**Recommended Net Volume:** 1.25 cu. ft. (35.4 ltrs.)

**Fc:** 43.5 Hz **F3:** 40.5 Hz **Qtc:** 0.763

**Front Baffle Thickness:** 1 in. (25 mm)

**Wall Thickness:** 0.75 in. (19 mm)

### PORTED ENCLOSURE:

**Recommended Net Volume:** 1.5 cu. ft. (42.5 ltrs.)

**Recommended Port Tuning:** 35.3 Hz

**Port Type:** "Slot" ports are recommended. See information above.

The port recommendations listed above are derived through actual tests and measurements (not computer simulations).

**Front Baffle Thickness:** 1 in. (25 mm)

**Wall Thickness:** 0.75 in. (19 mm)



# 12W7AE-3

- Free Air Resonance (Fs):** 27.2 Hz
- Electrical "Q" (Qes):** 0.514
- Mechanical "Q" (Qms):** 7.807
- Total Speaker "Q" (Qts):** 0.482
- Equivalent Compliance (Vas):** 2.33 cu. ft. (66.0 ltrs)
- One-Way, Linear Excursion (Xmax)\*:** 1.15 in. (29 mm)
- Thermal Power Handling (Pt):** 1000 Watts Continuous
- Reference Efficiency (no):** 0.249 %
- Efficiency (SPL @ 1W/1m):** 86.2 dB
- DC Resistance (Re):** 2.47Ω
- Effective Piston Area (Sd):** 84 sq. in. (0.0542 sq. m)
- Nominal Impedance (Znom):** 3Ω

\* Xmax specifications are derived via one-way voice coil overhang method with no correction factors applied.



### RECOMMENDED CONTINUOUS (RMS) POWER RANGE FOR ONE SUBWOOFER DRIVER:





## 12W7AE Subwoofer: Driver & Enclosure Specifications

**Grille Clearance:** 2.6 in. (66 mm) from the bottom of the mounting flange to the lowest inside surface of the grille.

**Displacement:** 0.14 cu. ft. (4.0 ltrs)

**Net Weight:** 45 lbs. (20.4 kg)

**Mounting Hardware:** Twelve #10 x 1.75" long clear, zinc-plated steel Phillips pan-head sheet metal screws (included) **or** twelve #10-32 long steel Phillips pan-head machine screws with #10-32 T-Nuts, each at least 1/2-inch (12.5 mm) longer than the thickness of the mounting baffle (not included).

**Unpacking/Mounting:** Please refer to the "How to: Mount a W7AE Subwoofer" on pages 4 & 5 for detailed, step-by-step instructions.

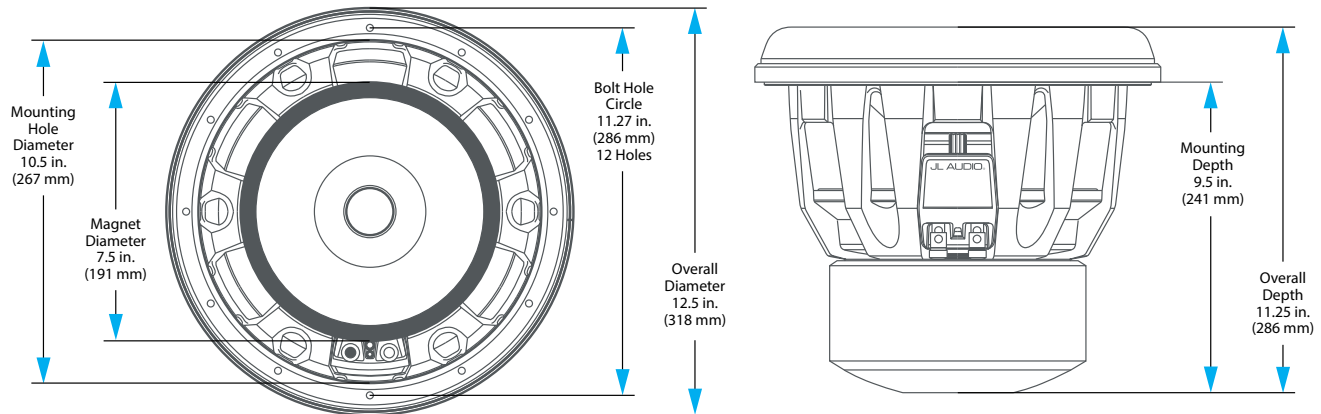

Net volumes given below do not include the air volume displaced by the speaker (Driver Displacement). This value must be added to the net volume along with the displacement of any braces and/or ports (if applicable) to arrive at a gross internal volume. Air inside a port is not part of the effective net volume. Calculate ports as solid, not hollow objects.

The dimensions given for the enclosure examples below take all applicable displacements into consideration.

### SAFETY NOTICE!

It is absolutely essential that the completed subwoofer enclosure is mounted firmly to the vehicle with heavy steel bolts (1/2 inch diameter) and large steel washers on both sides of the bolts. This will reduce the likelihood of occupant injury in the event of a collision or sudden deceleration.

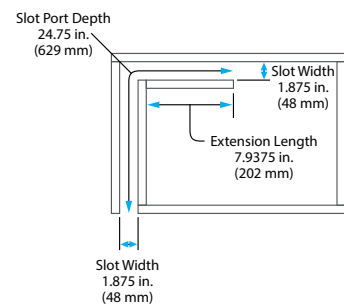
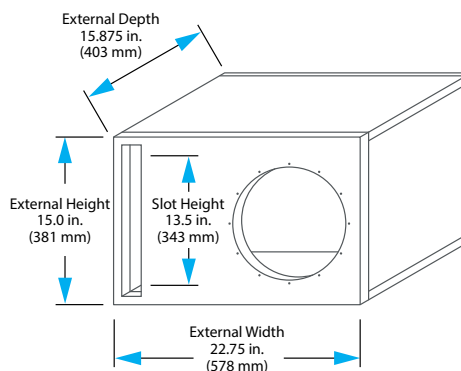
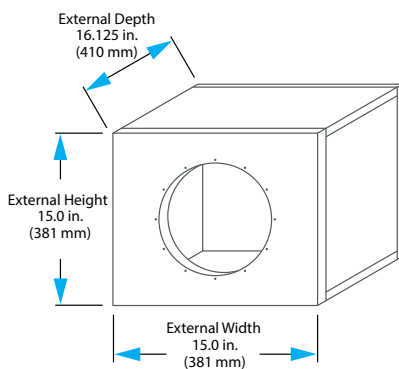

### SEALED ENCLOSURE:

**Recommended Net Volume:** 1.375 cu. ft. (38.94 ltrs.)

**Fc:** 44.7 Hz **F3:** 40.4 Hz **Qtc:** 0.791

**Front Baffle Thickness:** 1 in. (25 mm)

**Wall Thickness:** 0.75 in. (19 mm)

### PORTED ENCLOSURE:

**Recommended Net Volume:** 1.75 cu. ft. (51.54 ltrs.)

**Recommended Port Tuning:** 36.7 Hz

**Port Type:** "Slot" ports are recommended. See information above.

The port recommendations listed above are derived through actual tests and measurements (not computer simulations).

**Front Baffle Thickness:** 1 in. (25 mm)

**Wall Thickness:** 0.75 in. (19 mm)



# 13W7AE-D1.5

- Free Air Resonance (Fs):** 23.5 Hz
- Electrical "Q" (Qes):** 0.476
- Mechanical "Q" (Qms):** 7.517
- Total Speaker "Q" (Qts):** 0.448
- Equivalent Compliance (Vas):** 3.68 cu. ft. (104.3 ltrs)
- One-Way, Linear Excursion (Xmax)\*:** 1.25 in. (32 mm)
- Thermal Power Handling (Pt):** 1500 Watts Continuous
- Reference Efficiency (no):** 0.269 %
- Efficiency (SPL @ 1W/1m):** 86.3 dB
- DC Resistance (Re):** 2.41Ω
- Effective Piston Area (Sd):** 107.35 sq. in. (0.0693 sq. m)
- Nominal Impedance (Znom):** Dual 1.5Ω



\* Xmax specifications are derived via one-way voice coil overhang method with no correction factors applied.  
 \*\* For parallel-wired voice coils, divide "Re" by 4.  
 All other specifications remain the same.



## RECOMMENDED CONTINUOUS (RMS) POWER RANGE FOR ONE SUBWOOFER DRIVER:





## 13W7AE Subwoofer: Driver & Enclosure Specifications

**Grille Clearance:** 2.7 in. (69 mm) from the bottom of the mounting flange to the lowest inside surface of the grille.

**Displacement:** 0.21 cu. ft. (5.9 ltrs)

**Net Weight:** 52 lbs. (23.6 kg)

**Mounting Hardware:** Twelve #12 x 1.75" long clear, zinc-plated steel Phillips pan-head sheet metal screws (included) **or** twelve #12-28 long steel Phillips pan-head machine screws with #12-28 T-Nuts, each at least 1/2-inch (12.5 mm) longer than the thickness of the mounting baffle (not included).

**Unpacking/Mounting:** Please refer to the "How to: Mount a W7AE Subwoofer" on pages 4 & 5 for detailed, step-by-step instructions.

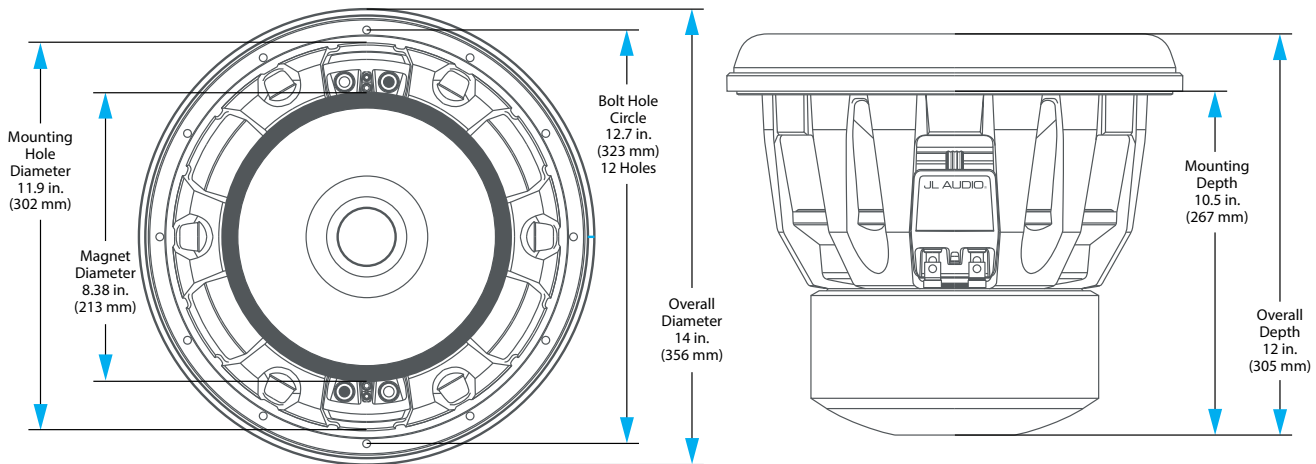

Net volumes given below do not include the air volume displaced by the speaker (Driver Displacement). This value must be added to the net volume along with the displacement of any braces and/or ports (if applicable) to arrive at a gross internal volume. Air inside a port is not part of the effective net volume. Calculate ports as solid, not hollow objects.

The dimensions given for the enclosure examples below take all applicable displacements into consideration.

### SAFETY NOTICE!

It is absolutely essential that the completed subwoofer enclosure is mounted firmly to the vehicle with heavy steel bolts (1/2 inch diameter) and large steel washers on both sides of the bolts. This will reduce the likelihood of occupant injury in the event of a collision or sudden deceleration.

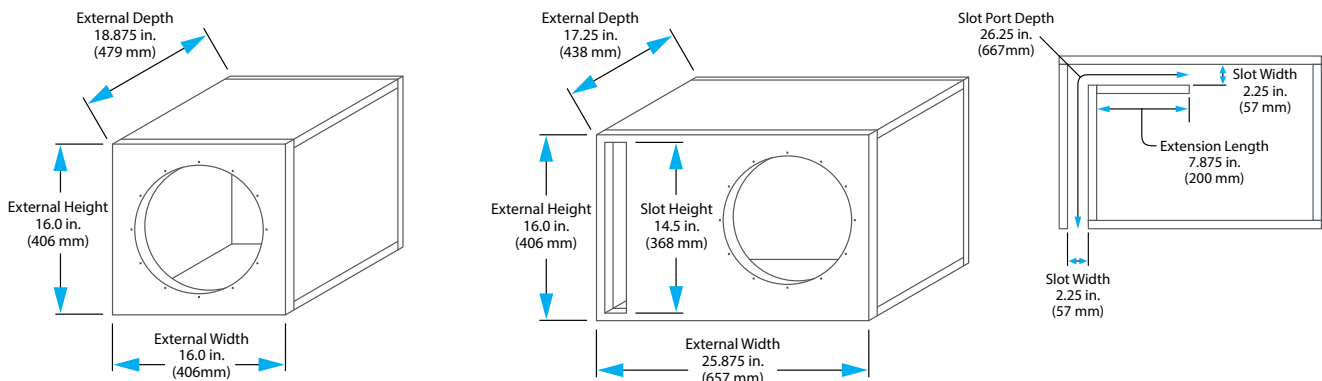

### SEALED ENCLOSURE:

**Recommended Net Volume:** 1.875 cu. ft. (53.1 ltrs.)

**Fc:** 40.5 Hz **F3:** 37.4 Hz **Qtc:** 0.770

**Front Baffle Thickness:** 1 in. (25 mm)

**Wall Thickness:** 0.75 in. (19 mm)

### PORTED ENCLOSURE:

**Recommended Net Volume:** 2.375 cu. ft. (67.3 ltrs.)

**Recommended Port Tuning:** 34.6 Hz

**Port Type:** "Slot" ports are recommended. See information above.

The port recommendations listed above are derived through actual tests and measurements (not computer simulations).

**Front Baffle Thickness:** 1 in. (25 mm)

**Wall Thickness:** 0.75 in. (19 mm)



## 13W7AE Subwoofer: Dual Voice Coil Wiring

The 13W7AE-D1.5 employs dual 1.5Ω voice coils. **BOTH** voice coils must be connected to the amplifier for proper operation. Connecting only one voice coil will result in poor performance and is **NEVER** recommended.

Wiring the dual voice coils in series to achieve a 3Ω load to the amplifier is the most common wiring method:

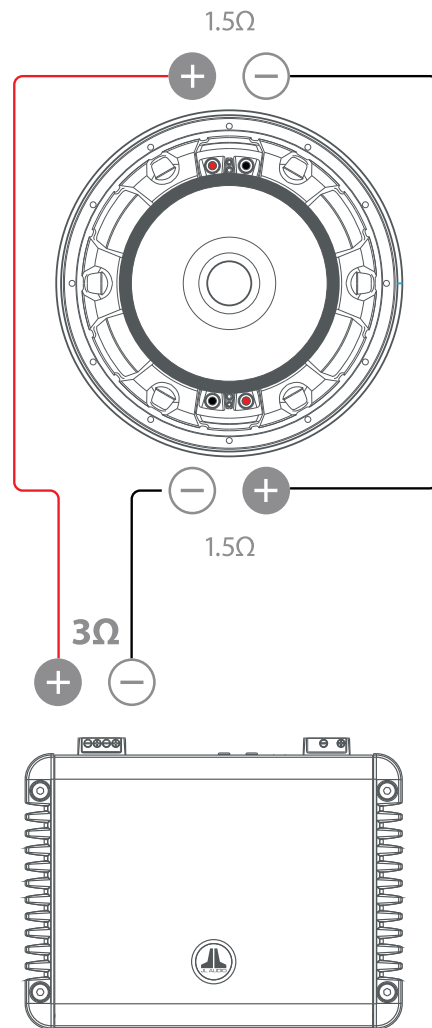

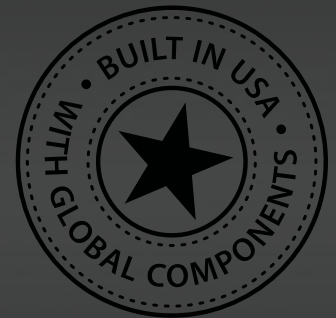

## Limited Warranty

JL AUDIO warrants this speaker to be free of defects in materials and workmanship for a period of one (1) year from the original date of purchase.

This warranty is not transferrable and applies only to the original purchaser of the product from an authorized JL AUDIO dealer. Should service be necessary under this warranty for any reason due to manufacturing defect or malfunction, JL AUDIO will, at its discretion, repair or replace the defective product with new or remanufactured product at no charge.

Damage caused by the following is not covered under warranty: accident, misuse, abuse, product modification or neglect, failure to follow installation instructions, unauthorized repair attempts, misrepresentations by the seller. This warranty does not cover incidental or consequential damages and does not cover the cost of removing or reinstalling the unit(s). Cosmetic damage due to accident or normal wear and tear is not covered under warranty.

Any applicable implied warranties are limited in duration to the period of the express warranty as provided herein beginning with the date of the original purchase at retail, and no warranties, whether express or implied, shall apply to this product thereafter. Some states do not allow limitations on implied warranties, therefore these exclusions may not apply to you. This warranty gives you specific legal rights, and you may also have other rights which vary from state to state.

### If you need service on your JL AUDIO product:

All warranty returns should be sent to JL AUDIO freight prepaid through an authorized JL AUDIO dealer and must be accompanied by proof of purchase (a copy of the original sales receipt). Direct returns from consumers or non-authorized dealers will be refused unless specifically authorized by JL AUDIO with a valid return authorization number. Warranty expiration on products returned without proof of purchase will be determined from the manufacturing date code. Coverage may be invalidated as this date is previous to purchase date. Return only defective components. Non-defective items received will be returned freight-collect. The customer is responsible for shipping charges and insurance in sending the product to JL AUDIO. Freight damage on returns is not covered under warranty. Always include proof of purchase (sales receipt).

### For Service Information in the U.S.A. please call:

JL Audio customer service: (954) 443-1100 during normal business hours (Eastern Time)

### JL Audio, Inc

10369 North Commerce Parkway, Miramar, FL 33025

### International Warranties:

Products purchased outside the United States of America are covered only by that country's distributor and not by JL Audio, Inc.



How we play.®

[www.jlaudio.com](http://www.jlaudio.com)

10369 North Commerce Parkway • Miramar, Florida • 33025 • USA

©2018 JL Audio, Inc. "How we play", "JL Audio" and the JL Audio logo are registered trademarks of JL Audio, Inc. "W7AE", "OverRoll", "W-Cone" and their respective logos are trademarks of JL Audio, Inc.

For more detailed information please visit us online at [www.jlaudio.com](http://www.jlaudio.com).

Due to our policy of continuous product development, all specifications are subject to change without notice.

SKU#011171 04-2018  
Printed in U.S.A.

