

Before installing make sure ignition supply to the vehicle is switched off !

Dashboard Disassembly

1. Unclip and remove the recirculate/ fresh slide button. (Figure A)
2. Unclip and remove the entire panel surrounding the radio including the a/c vents. (Figure B)
3. Remove (4) Phillips screws securing the radio. (Figure C)

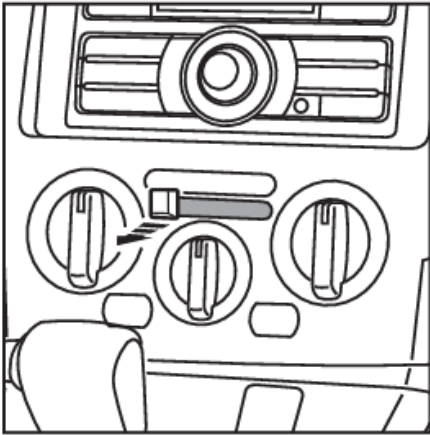

(Figure A)

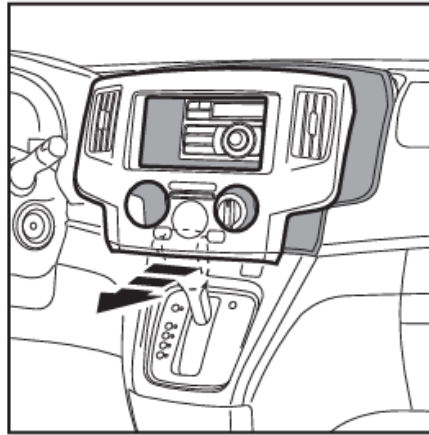

(Figure B)

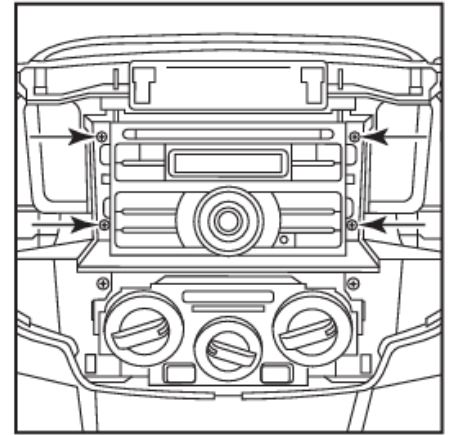

(Figure C)

Assembling the patch lead (29-025)



Look at the diagrams

1. Look at the diagrams below
2. Use either the 3.5mm jack plug or the single Brown wire in pin locations 1,2 & 3
3. Use the link leads to suit the type of head unit you are fitting.
4. Carefully lift the latch on the plastic housing to remove a link lead

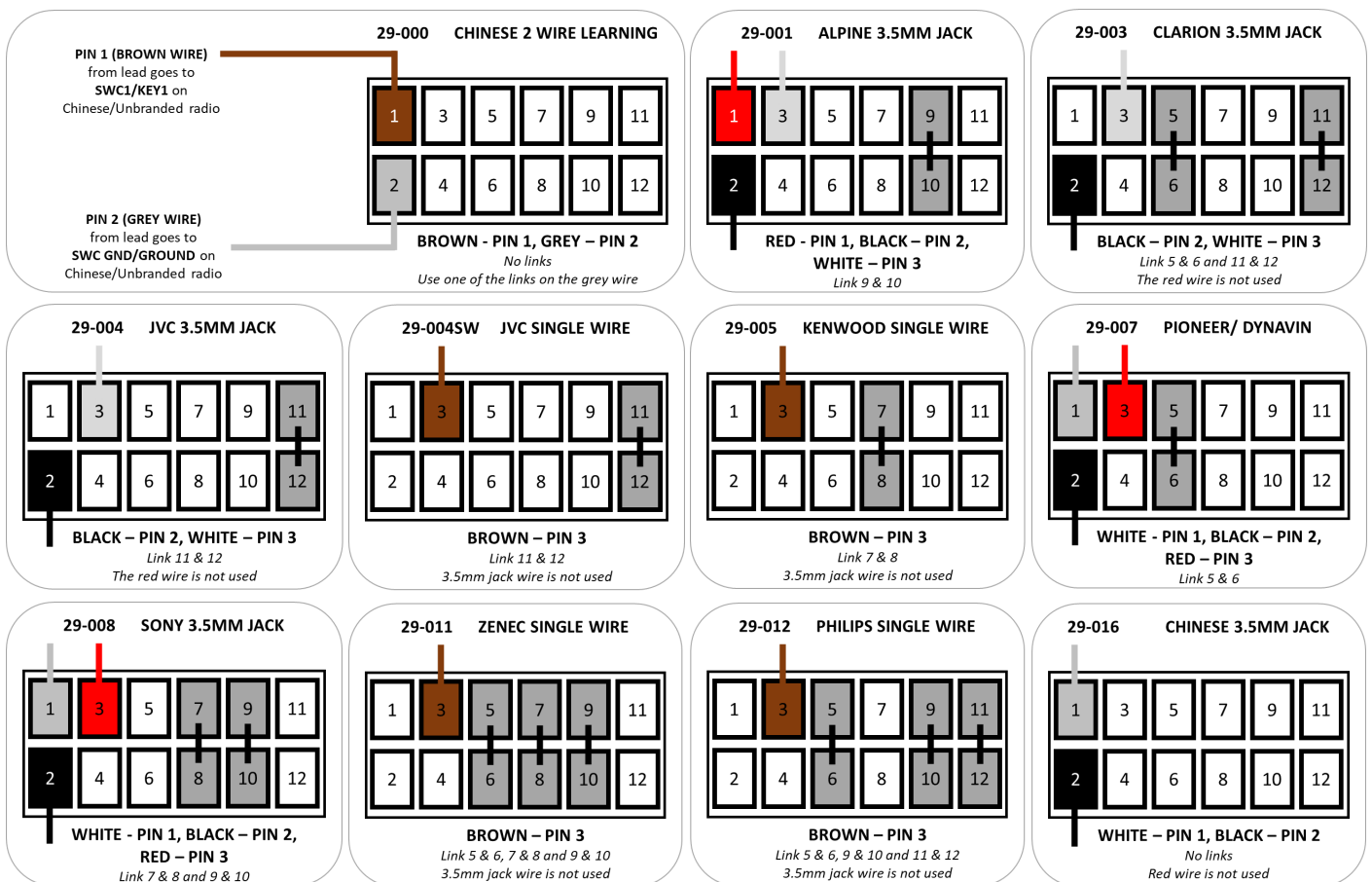

Connecting the patch lead (3.5mm Jack)

1. Connect the patch lead to the 29-Series interface controller before connecting anything else
2. Connect the 3.5mm jack to the back of the new aftermarket head unit. This is labelled differently depending on the brand of head unit, For e.g. Alpine/ Sony is usually labelled Remote, Pioneer SWC or W/R. Please refer to the manufacturers instructions to confirm this
3. Some interface boxes will have a 4-pin connector branching from the interface. This is the connector for the software update controller and does not need to be plugged into anything for the installation.

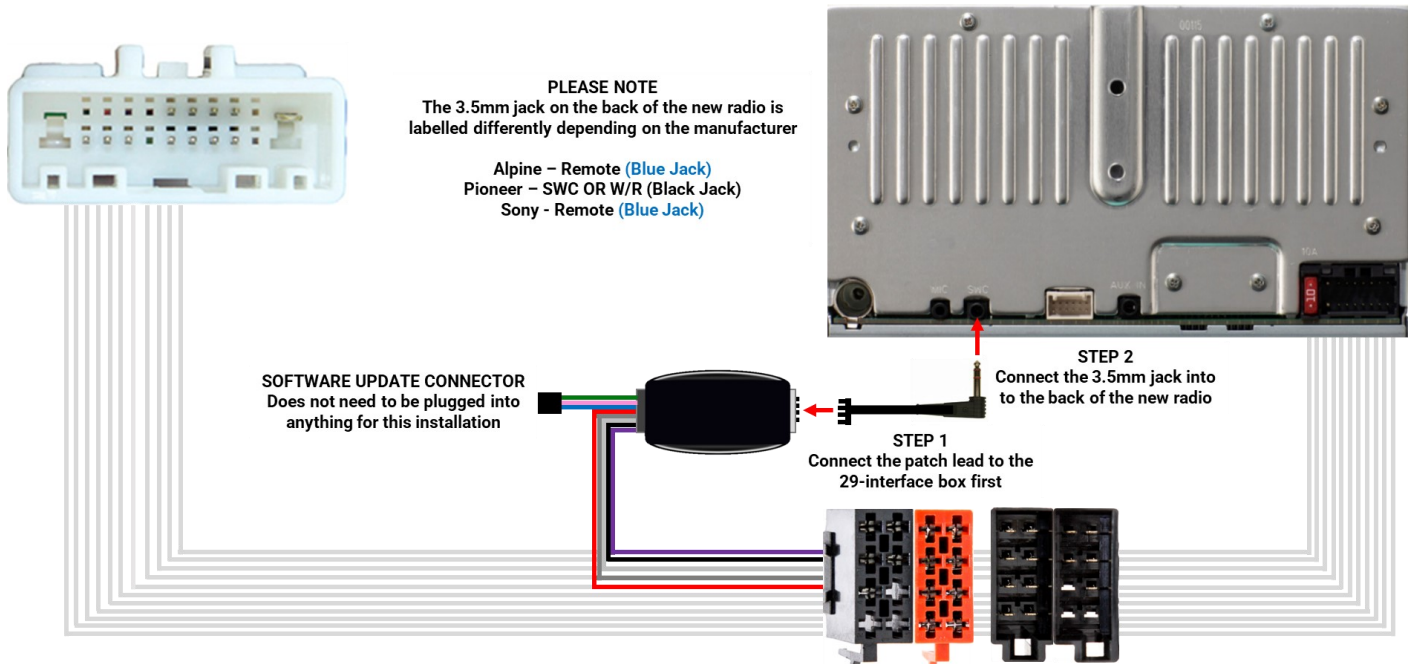

Connecting the patch lead (Loose Wire)

1. Connect the patch lead to the 29-Series interface controller before connecting anything else
2. Connect the loose brown wire to the steering remote wire on the new radio, this can either be on the back of the new aftermarket head unit or on the new radio cable. This is labelled differently depending on the brand of head unit. Please refer to the manufacturers instructions to confirm this
3. Some interface boxes will have a 4-pin connector branching from the interface. This is the connector for the software update controller and does not need to be plugged into anything for the installation.

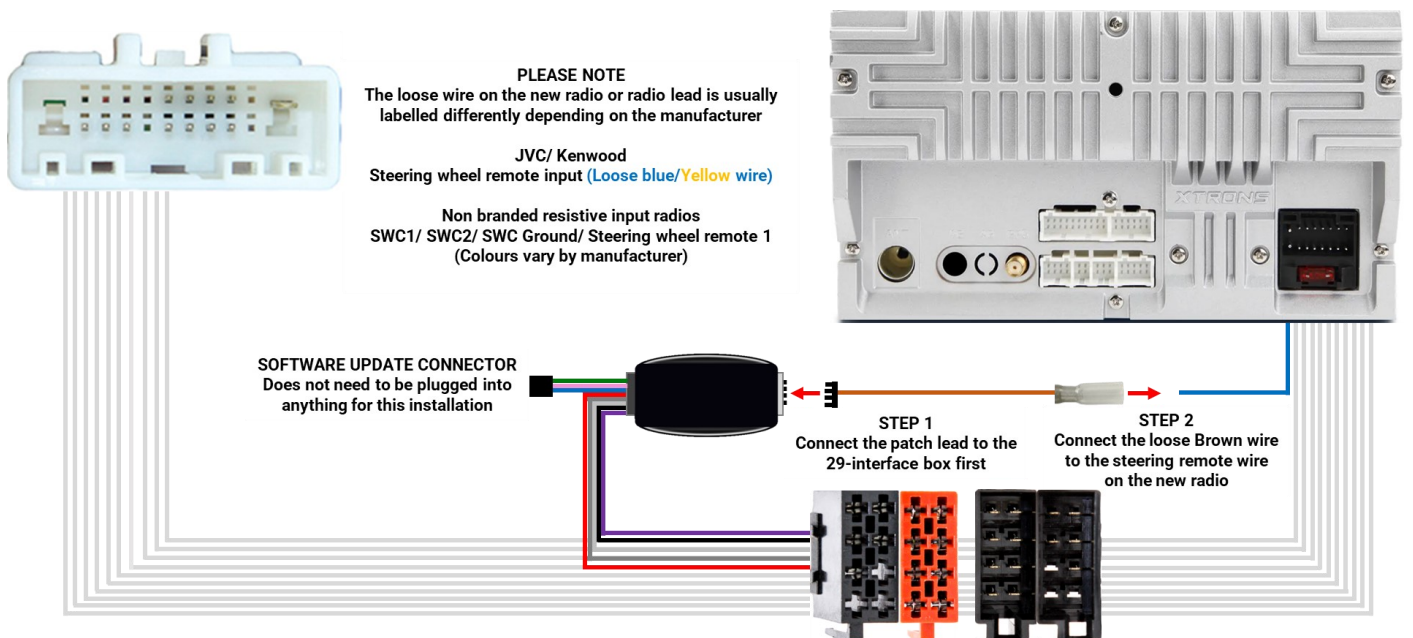

Steering wheel control interface (29-671) installation

1. Connect the black and brown male ISO connections to the corresponding female ISO connections from the back of the radio. If your radio has loose wires rather than ISO connections, please use an ISO adapter such as a Incartec 20-022 to add them to your radio.
2. Connect the vehicle specific connectors into the cars original wiring. Connect the ground loop that is attached to the harness (the main earth lead for the radio) to a chassis ground on the vehicle.
3. If your aftermarket radio has a speed pulse output then connect this to the Pink Speed Pulse on the steering wheel control interface.
4. The amplifier turn on cable is only to be used for amplified sound systems and so is not required.

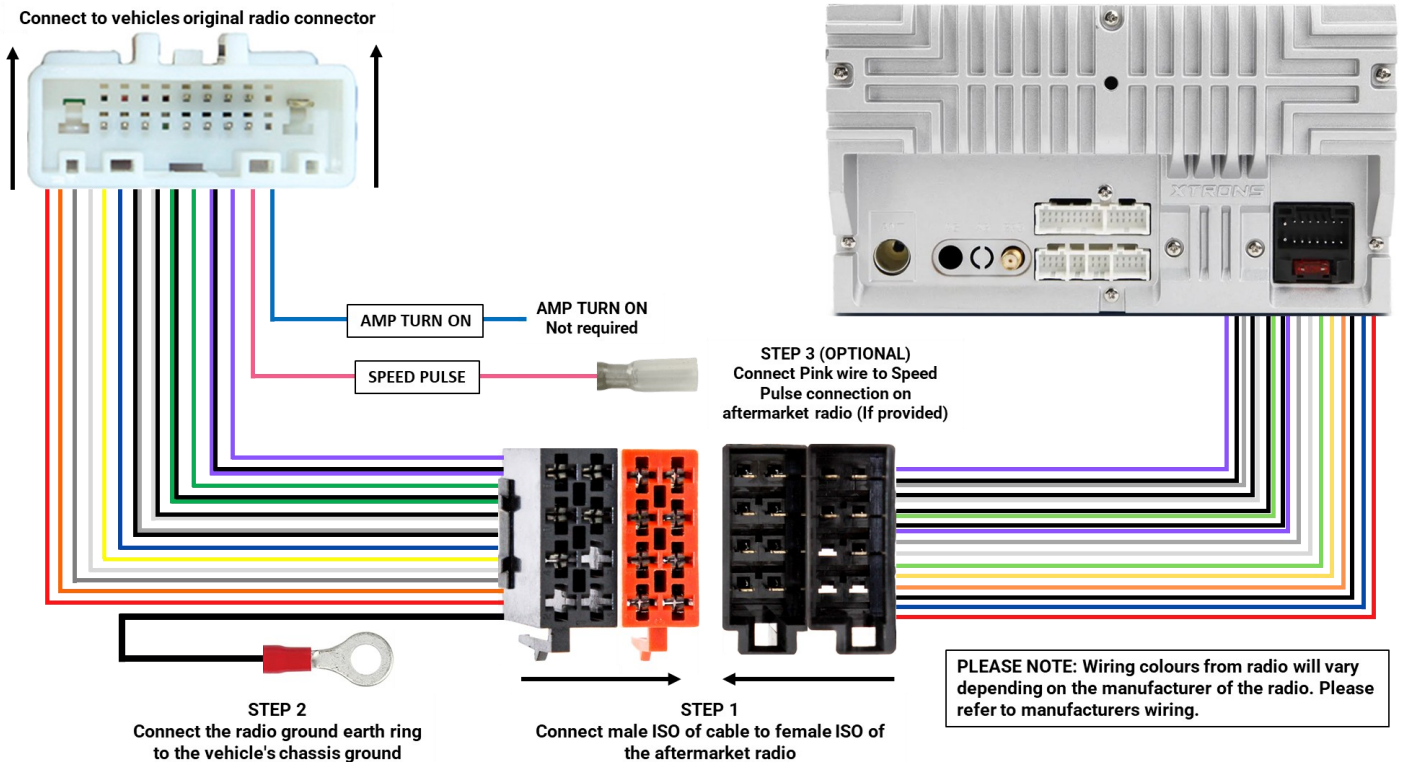

Antenna adapter (21-118K) installation

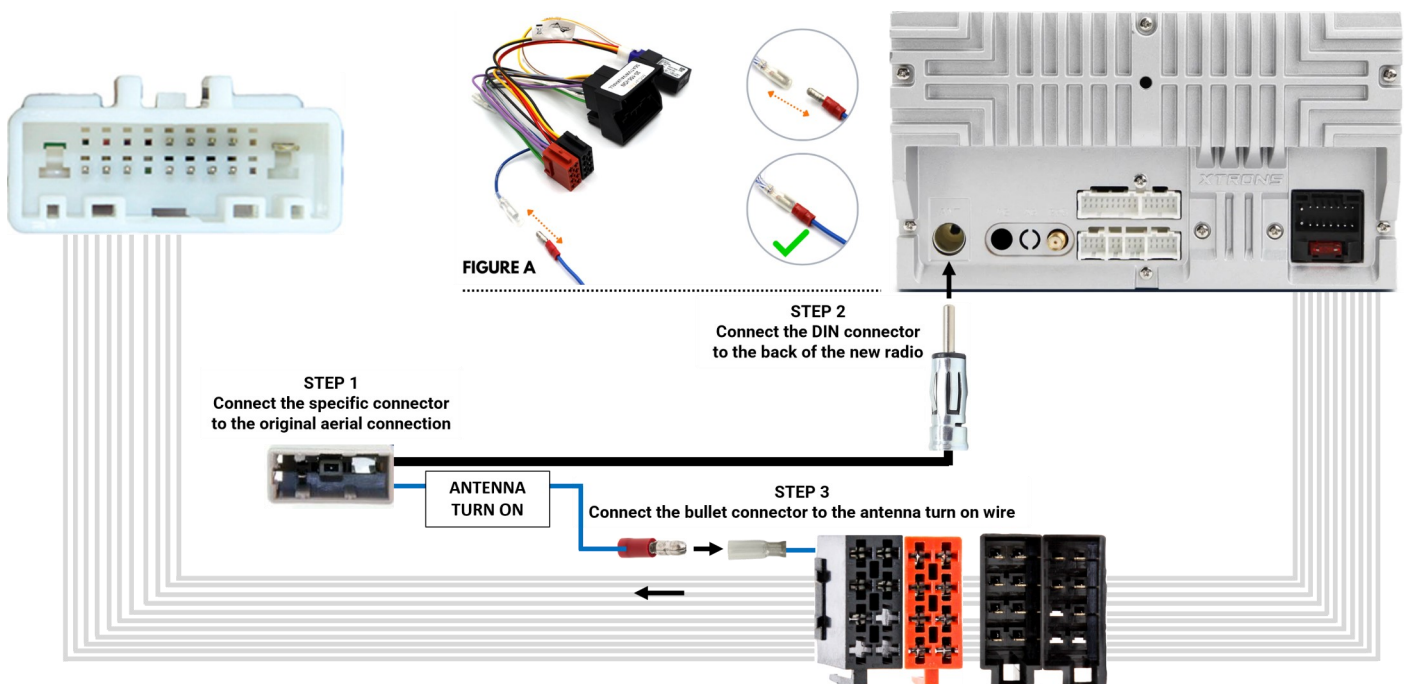

! Test the aftermarket unit fully, ensuring all the functions are working properly before fixing the new head unit into the dashboard !

Aftermarket fascia (50-644) assembly

1. Attach the radio brackets to the new radio trim panel (Figure A)
2. If fitting a Single DIN radio, mount the pocket to the bracket/ trim panel assembly with the (4) #8 x 3/8" Philips screws supplied. (Figure B)
3. Slide the radio into the assembly and secure with screws supplied with the radio. (Figure C)
4. Mount the new radio into the dash and reassemble the original panels in the reverse order of disassembly.

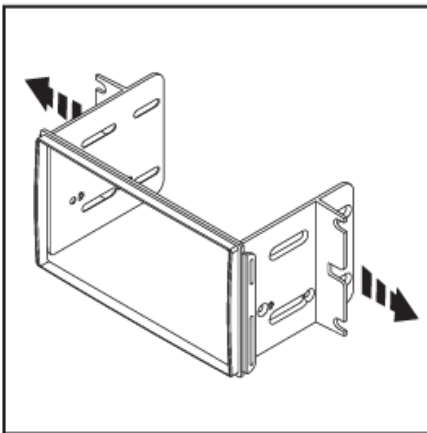

(Figure A)

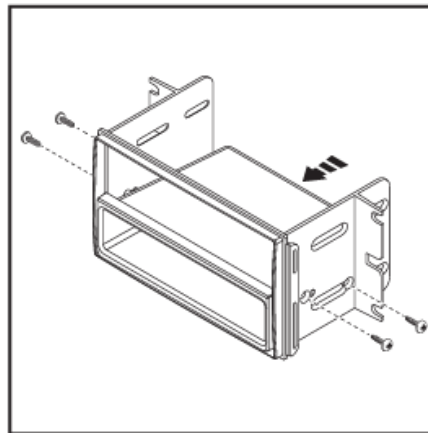

(Figure B)

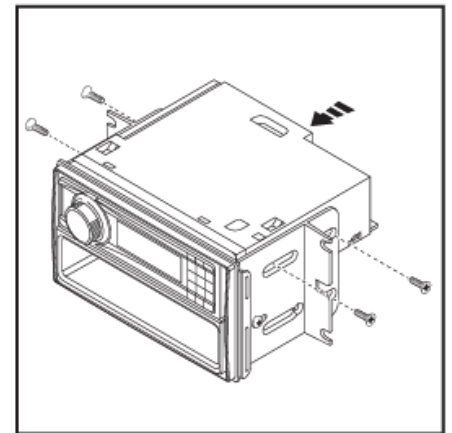

(Figure C)

Trouble Shooting

- Check that the correct adapter has been used and patch lead links are in the correct place (Always disconnect from the power supply before making any changes to the lead)
- Check that the red wire in the main harness is a 12v ignition and not permanent power
- Check that the head unit is earthed and that the black wire is earth