

Video inserter

27-587 (RL4-MBMRT)

Compatible with

Mercedes Benz

Actros 5 und Arocs vehicles

with Classic Cockpit with Multimedia Radio Touch with 7inch monitor or Multimedia Cockpit with 10.25inch monitor without navigation and with 26pin radio connector



example

**Video-inserter for front- and rear-view camera
and two more video inputs**

Product features

- Video-inserter for factory-infotainment systems
- 1 CVBS Input for rear-view camera
- 1 CVBS Input for front camera
- 2 CVBS Video-inputs for after-market Video sources (e.g. DVD-Player, DVB-T Tuner)
- Automatic switching to rear-view camera input on engagement of the reverse gear
- Automatic front camera switching after reverse gear for 10 seconds
- Video-in-motion (ONLY for connected video-sources)
- Video-inputs NTSC compatible

Contents

1. Prior to installation

- 1.1. Delivery contents
- 1.2. Checking the compatibility of vehicle and accessories
- 1.3. Boxes and connectors – video interface
- 1.4. Settings of the 8 Dip switches (black)
 - 1.4.1. Adjustment – power supply output (dip 1)
 - 1.4.2. Enabling the interface's video inputs (dip 2-3)
 - 1.4.3. Rear-view camera settings (dip 5)
 - 1.4.4. Activation – front camera back-switching (dip6)
 - 1.4.5. Monitor selection (Dip 8)
- 1.5. Settings - 6 Dip switches (Top of box–black)
- 1.6. Settings of the 4 Dip switches (CAN function – red)

2. Installation

- 2.1. Place of installation
- 2.2. Connection schema
- 2.3. Connection – picture signal cable
- 2.4. Installation with connection to CAN bus or analogue (without CAN bus)
 - 2.4.1. Connection – 26pin PNP cable (with CAN-bus)
 - 2.4.2. Special case: Head-unit with 31pin connector
 - 2.4.3. Connection - 26pin PNP cable (analogue without CAN-bus)
 - 2.4.3.1. Connection – switching input by 12pin Power cable (with analogue connection without CAN-Bus)
 - 2.5. Connection – reverse signal (analogue)
 - 2.6. Power supply -After-market rear-view camera and after-market front camera
 - 2.7. Power supply output
 - 2.8. Connection - video-interface and external keypad
 - 2.9. Connection - video-sources
 - 2.10. Audio insertion
 - 2.11. Picture settings

3. Interface operation

4. Specifications

5. FAQ – Trouble Shooting-Interface functions

6. Technical support

Legal Information

By law, watching moving pictures while driving is prohibited, the driver must not be distracted. We do not accept any liability for material damage or personal injury resulting, directly or indirectly, from installation or operation of this product. Apart from using this product in an unmoved vehicle, it should only be used to display fixed menus or rear-view-camera video when the vehicle is moving (for example the MP3 menu for DVD upgrades).

Changes/updates of the vehicle's software can cause malfunctions of the interface. Up to one year after purchase we offer free software-updates for our interfaces. To receive a free update, the interface has to be sent in at own cost. Wages for de-and reinstallation and other expenditures involved with the software-updates will not be refunded.

1. Prior to installation

Read the manual prior to installation. Technical knowledge is necessary for installation. The video interface's place of installation must be free of moisture and away from heat sources.

Before the final installation in the vehicle of the video sources, we recommend a test-run to ensure the compatibility of vehicle and interface. Due to changes in the production of the vehicle manufacturer there's always a possibility of incompatibility.

1.1. Delivery contents

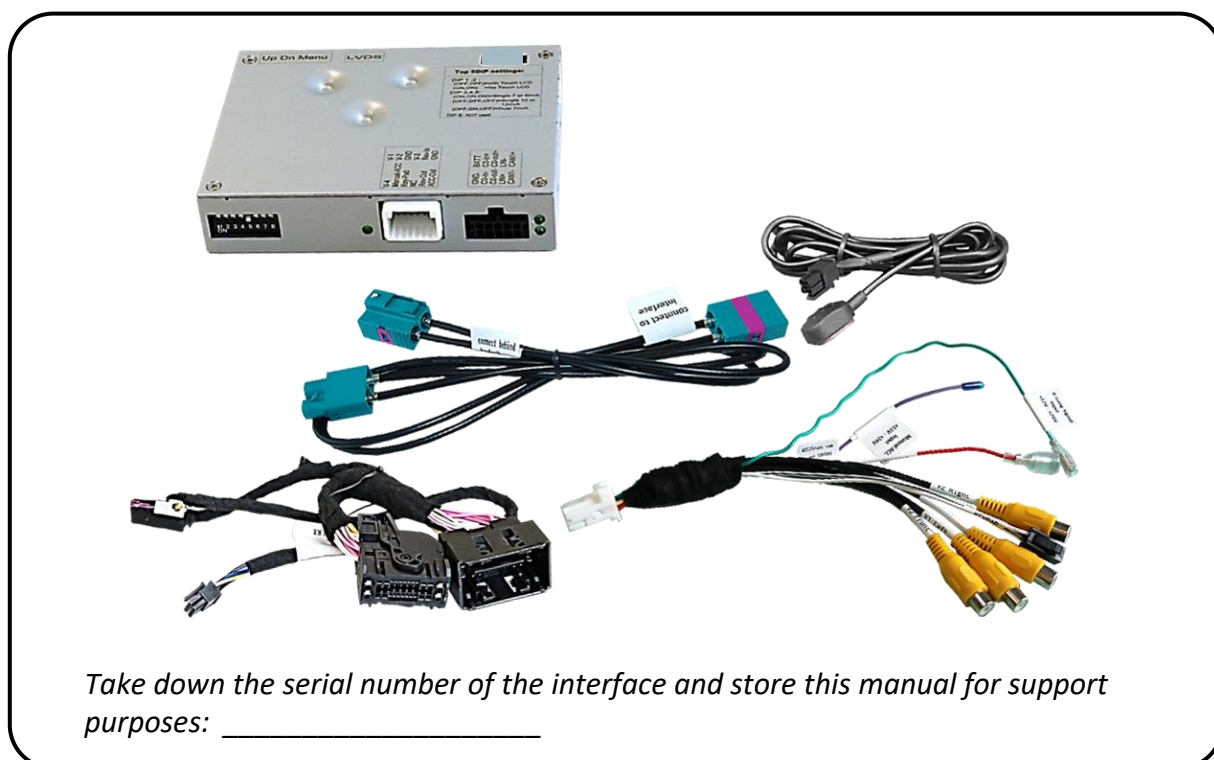

1.2. Checking the compatibility of vehicle and accessories

Requirements

Brand	Compatible vehicles	Infotainment
Mercedes Benz	Actros 5 since MY2018 Arocs since MY 2020	Classic Cockpit with Multimedia Radio Touch with 7inch monitor or Multimedia Cockpit with 10.25inch monitor without navigation and with 26pin radio connector*

Limitations:

Video only

The interface inserts ONLY video signals into the infotainment. For inserting Audio signals either the possibly existing factory audio-AUX-input or a FM-modulator can be used. If 2 audio sources shall be connected to the infotainment, an additional electronic is necessary to switch them.

Factory rear-view camera

Automatically switching-back from inserted video to factory rear-view camera is only possible while the reverse gear is engaged. To delay the switch-back an additional electronic part is required.

After market front camera

The front camera will automatically be switched for 10 seconds after disengaging the reverse gear. A manually front camera switching is possible by external keypad.

Video input signal

NTSC video sources compatible only.

**The multimedia cockpit with 10.25inch monitor without navigation has either the 26pin or a 31pin radio connector For the version with 31pin radio connector, the interface with the item number RL4-MBMC is available including a 31pin plug&play harness. Alternatively, the 26pin version RL4-MBMRT can also be used for the 31-pin variant by disconnecting the 26pin male and female connector of the plug&play cable and installing the open cable ends on the factory harness - this option is described as a "special case" in this manual.*

1.3. Boxes and connectors – video interface

The video-interface converts the connected after-market sources video signals into a LVDS signal which is inserted in the factory monitor using separate trigger options. Further it reads the vehicle's digital signals out of the vehicle's CAN-bus and converts them for the video interface.

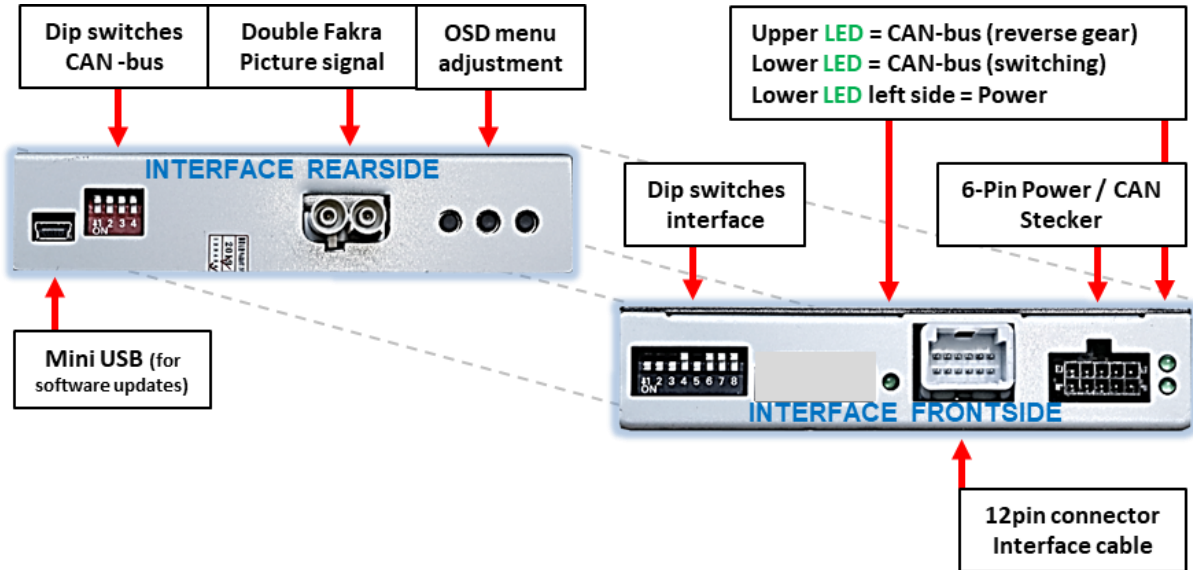

There are 2 different interface versions:

- Version **with** 6-dip switches on the top of the housing

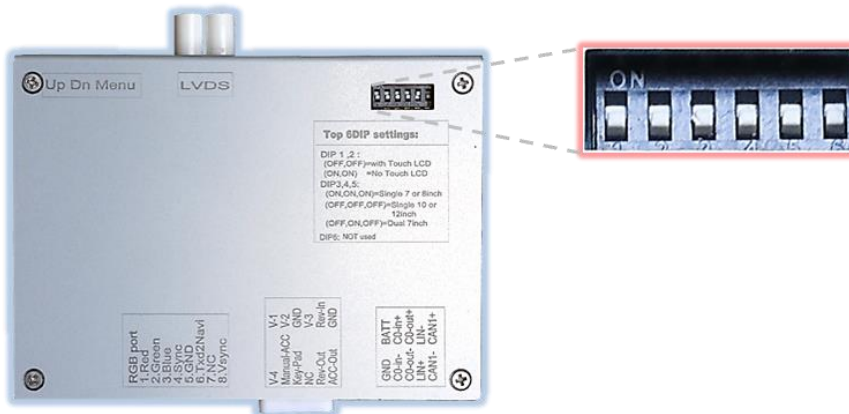

- Version **without** 6-dip switches on the top of the housing

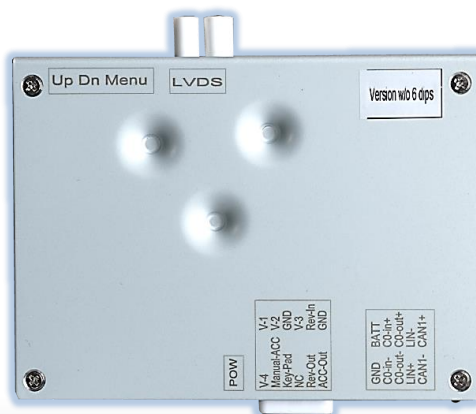

1.4. Settings of the 8 Dip switches (black)

Some settings have to be selected by the dip-switches on the video interface. Dip position **UP = OFF** and **DOWN = ON**.



Dip	Function	ON (down)	OFF (up)
1	Frontkamera	enabled*	disabled
	Power supply output (red wire)	+12V (max. 3A) when reverse gear is engaged incl. 10 seconds delay and +12V by manual switching to front camera by keypad	+12V (max. 3A) ACC
2	CVBS Video 1-input	enabled	disabled
3	CVBS Video 2-input	enabled	disabled
4	No function		set to OFF
5	Rear-view cam type	after-market	factory or none
6	*Frontcam back-switching for 10 seconds	*enabled	disabled
7	No function		set to OFF
8	Monitor selection		10.25inch monitor

*The front camera will automatically be switched for 10 seconds after disengaging the reverse gear.

See the following chapters for detailed information.

1.4.1. Adjustment – power supply output (dip 1)

If set to **ON**, the video interfaces' red wire will supply +12V (max 3A) with engaging the reverse gear and additionally 10 more seconds delay for the time of the front camera's back-switching after the reverse gear has been disengaged. Furthermore, the red wire's power supply for the front cam becomes active with manually front camera switching (short press of the external keypad).

If set to **OFF**, the video interfaces' red wire will supply permanent +12V ACC (max 3A).

Additional description of the power supply output: see chapter "Power supply output".

1.4.2. Enabling the interface's video inputs (dip 2-3)

Only the enabled video inputs can be accessed by switching through the interface's video sources. It is recommended to enable only the required inputs. Then the disabled inputs will be skipped while switching through the video interfaces inputs.

Note: Dip 4 is out of function and has to be set to **OFF!**

1.4.3. Rear-view camera settings (dip 5)

If set to **OFF**, the interface switches to factory picture while the reverse gear is engaged to display factory rear-view camera or factory optical park system picture.

If set to **ON**, the interface switches to its rear-view camera input while the reverse gear is engaged.

1.4.4. Activation – front camera back-switching (dip 6)

If set to **ON**, the interface switches for 10 seconds from the rear-view camera to the front camera input after having disengaged the reverse gear. In addition, a manual switch-over to the front camera input is possible via keypad (short press) from any image mode.

(Attend to correct adjustment of the power supply output (dip1)!

1.4.5. Monitor selection (Dip 8)

Dip switch 8 determines the type of monitor.

For the 10.25inch monitor, the dip switch position is **OFF**.

Note: Dip 4 and dip 7 are out of function and have to be set to **OFF!**

After each Dip-switch-change a power-reset of the interface box has to be performed!

1.5. Settings - 6 Dip switches (Top of box–black, if supported)

The 6 dip switches at the top of the video interface are responsible for the according monitor assignment.

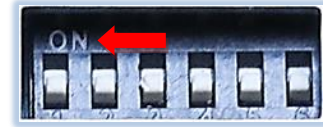

Attention: In contrast to both other dip benches (8dip and 4dip), the 6dip position **UP = ON** and **DOWN = OFF!**

Vehicle/Navigation	Dip 1	Dip 2	Dip 3	Dip 4	Dip 5	Dip 6
Actros 5 Multimedia Cockpit with navigation	OFF	OFF	OFF	OFF	OFF	OFF

After each Dip-switch-change a power-reset of the interface-box has to be performed!

1.6. Settings of the 4 Dip switches (CAN functions – red)

All 4 dip-switches of the video interface have no function for normal use and have to be set to OFF.

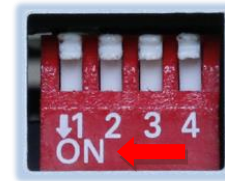

Dip position **UP = OFF** and **DOWN = ON.**

Vehicle/Navigation	Dip 1	Dip 2	Dip 3	Dip 4
Actros 5 Multimedia Cockpit with navigation	OFF	OFF	OFF	OFF

After each Dip-switch-change a power-reset of the interface-box has to be performed!

2. Installation

To install the interface, first switch off the ignition and disconnect the vehicle's battery. Please read the owner's manual of the car, regarding the battery's disconnection! If required, enable the car's Sleep-mode (hibernation mode) In case the sleep-mode does not succeed, the disconnection of the battery can be done with a resistor lead.

As with any installation of retrofit equipment, a stand-by test is necessary after the installation of the video interface, to ensure that the unit also switches off after reaching the vehicle's sleep mode.

Before the final installation, we recommend a test-run of the interface. Due to changes in the production of the vehicle manufacturer, there's always the possibility of incompatibility.

2.1. Place of installation

The video interface has to be installed near the head unit, which is located on the passenger side above the footwell.



Place of installation – Actros 5

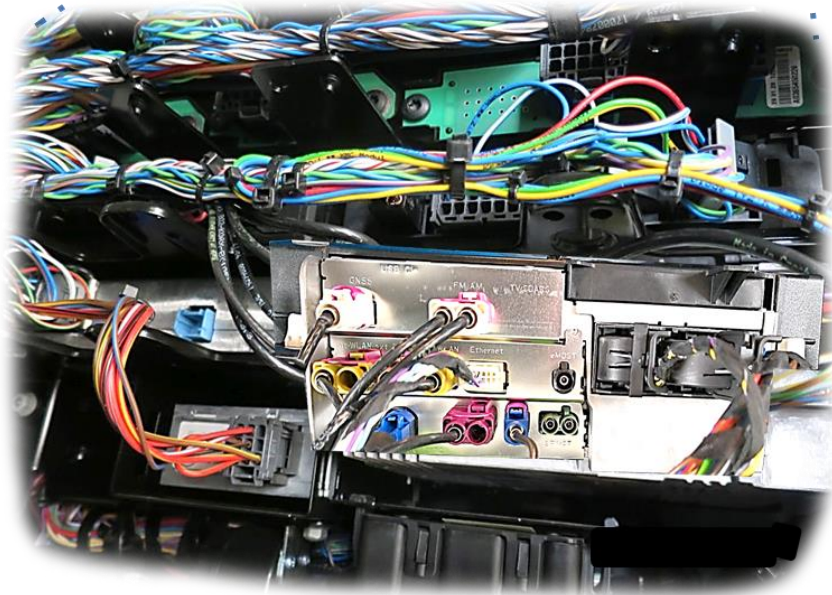

2.2. Connection schema

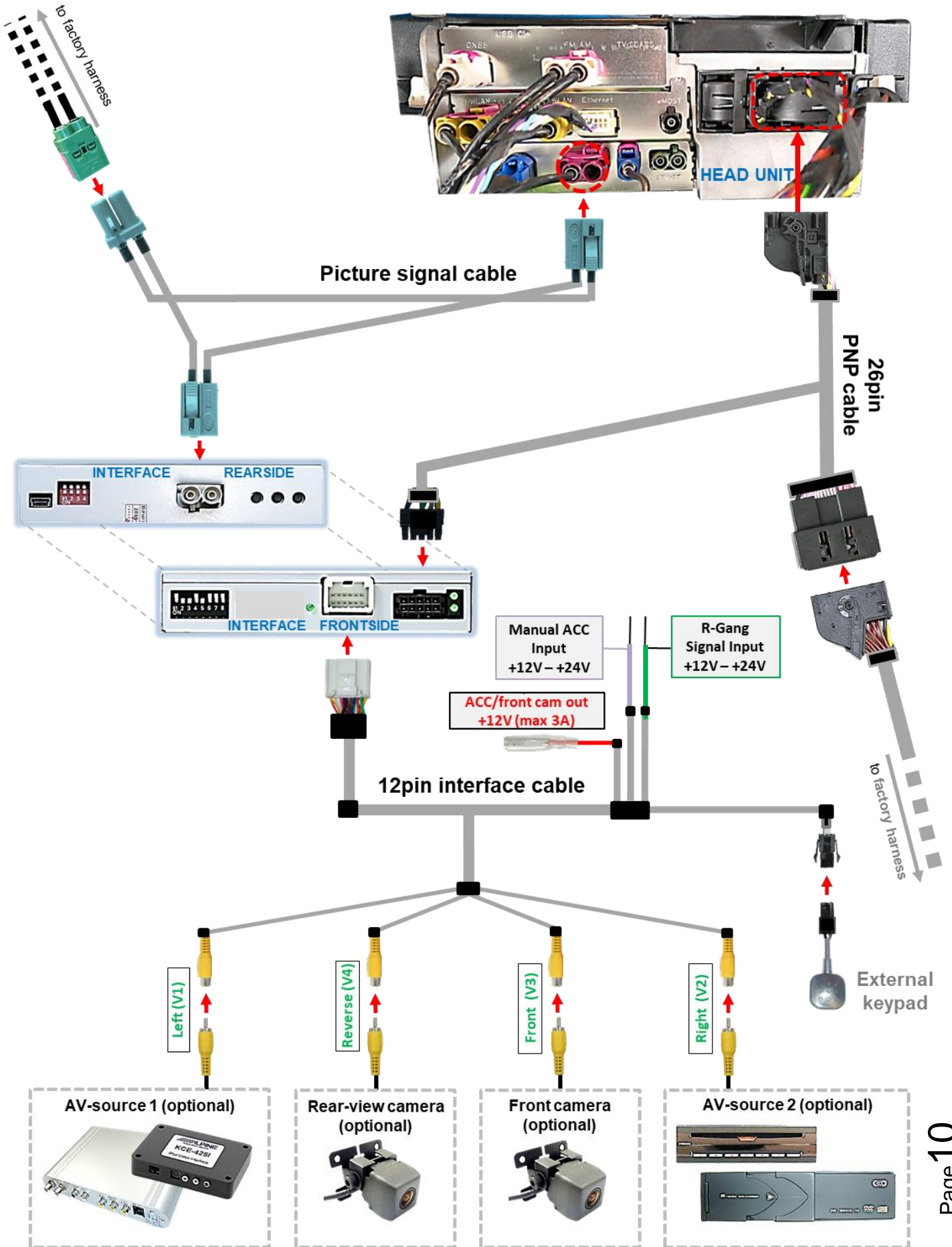

2.3. Connection – picture signal cable

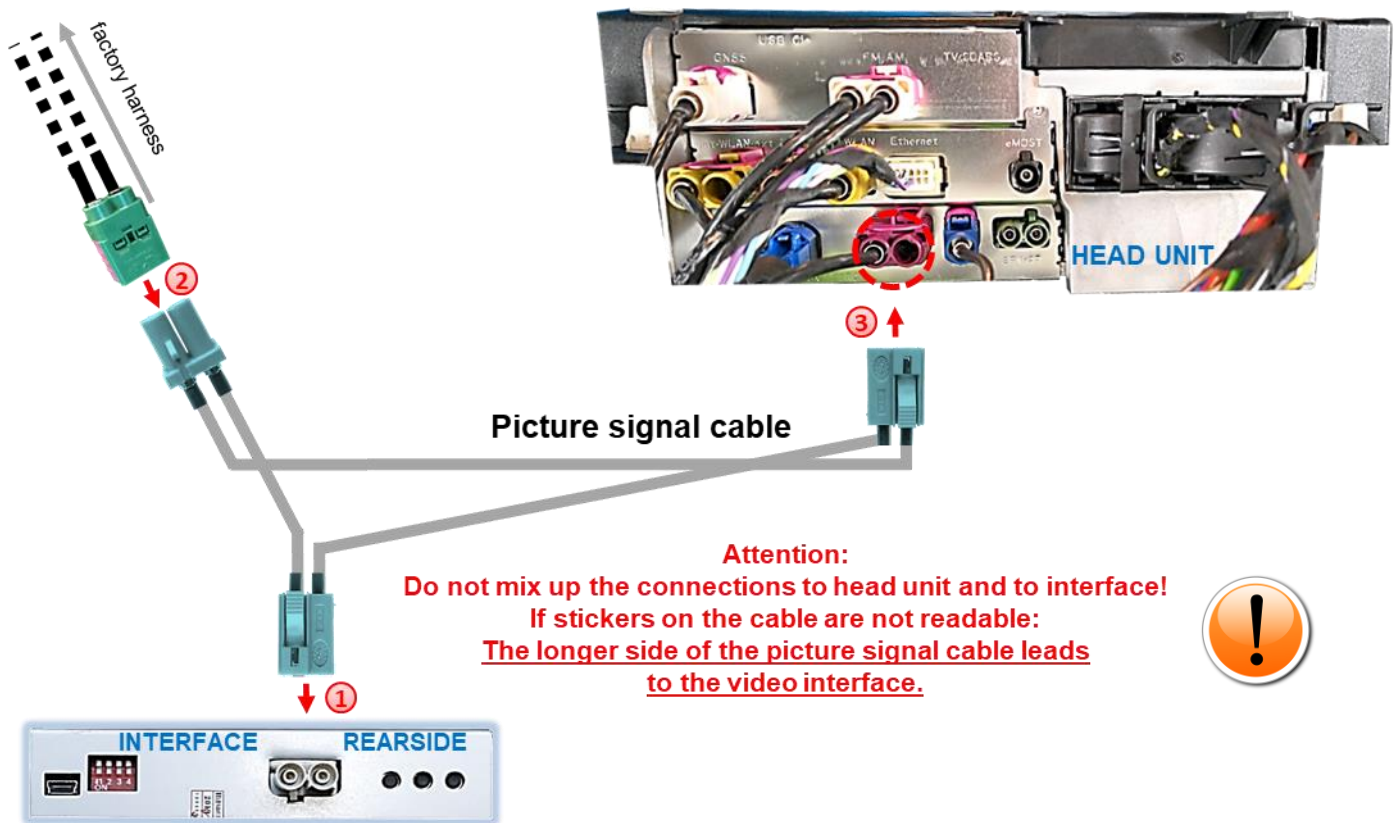

- 1 Connect the picture signal cable's waterblue coloured female double Fakra connector to the male double Fakra connector of the video interface.
- 2 Disconnect the female double Fakra connector at the head unit's male pink coloured double Fakra connector and connect it to the male waterblue coloured double Fakra connector of the enclosed picture signal cable.
- 3 Connect the picture signal cable's waterblue coloured female double-Fakra connector to the head-unit's previously become free pink coloured double-Fakra connector.

2.4. Installation with connection to CAN bus or analogue (without CAN bus)



Note: The RL4-MBMRT can be integrated via CAN bus as well as operated in analogue mode without CAN bus.

When integrated via CAN bus by the 26pin PNP cable, the interface is switched on by the vehicle's CAN-Bus.

In case of CAN bus incompatibility or to comply with vehicle manufacturer policies, an analogue connection without using the vehicle's CAN-BUS is also possible. In this case, via +12V switch inputs, the interface is switched on

(see **"Connection - 26pin PNP cable analogue without CAN-bus"**)

or, **"Connection - 10pin power cable analogue without CAN-Bus"**.

2.4.1 Connection - 26pin PNP cable (with CAN-bus)

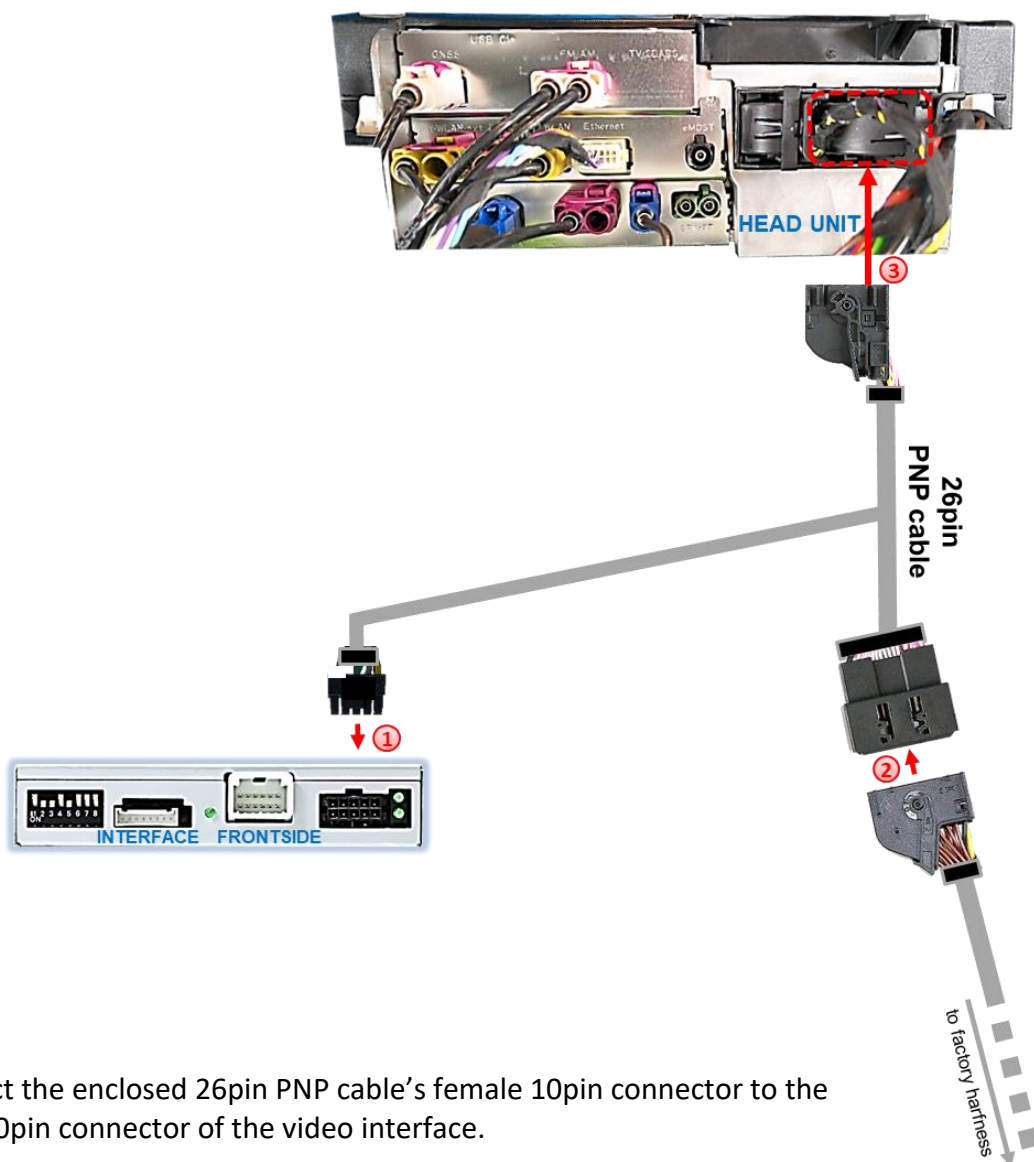

- 1 Connect the enclosed 26pin PNP cable's female 10pin connector to the male 10pin connector of the video interface.
- 2 Disconnect the female 26pin connector of the factory harness at the rear-side of the head-unit and connect it to the male 26pin connector of the enclosed 26pin PNP cable.
- 3 Connect the opposite female 26pin connector of the enclosed 26pin PNP cable to the previously become free male 26pin connector of the factory head-unit.

2.4.2 Special case – Head-unit with 31pin connector

In exceptional cases, head units with 31pin connectors (instead of 26-pin connectors) were installed by the manufacturer. In this case, the female 31pin locking connector of the factory harness remains connected to the male 31pin locking connector of the factory head unit and the corresponding power and CAN cables of the enclosed 26pin PNP cable must additionally be connected to the factory harness. For this purpose, the unneeded PNP section of the enclosed 26-pin PNP cable must be cut off.

The pin assignments of the locking connectors are shown in the diagram below.

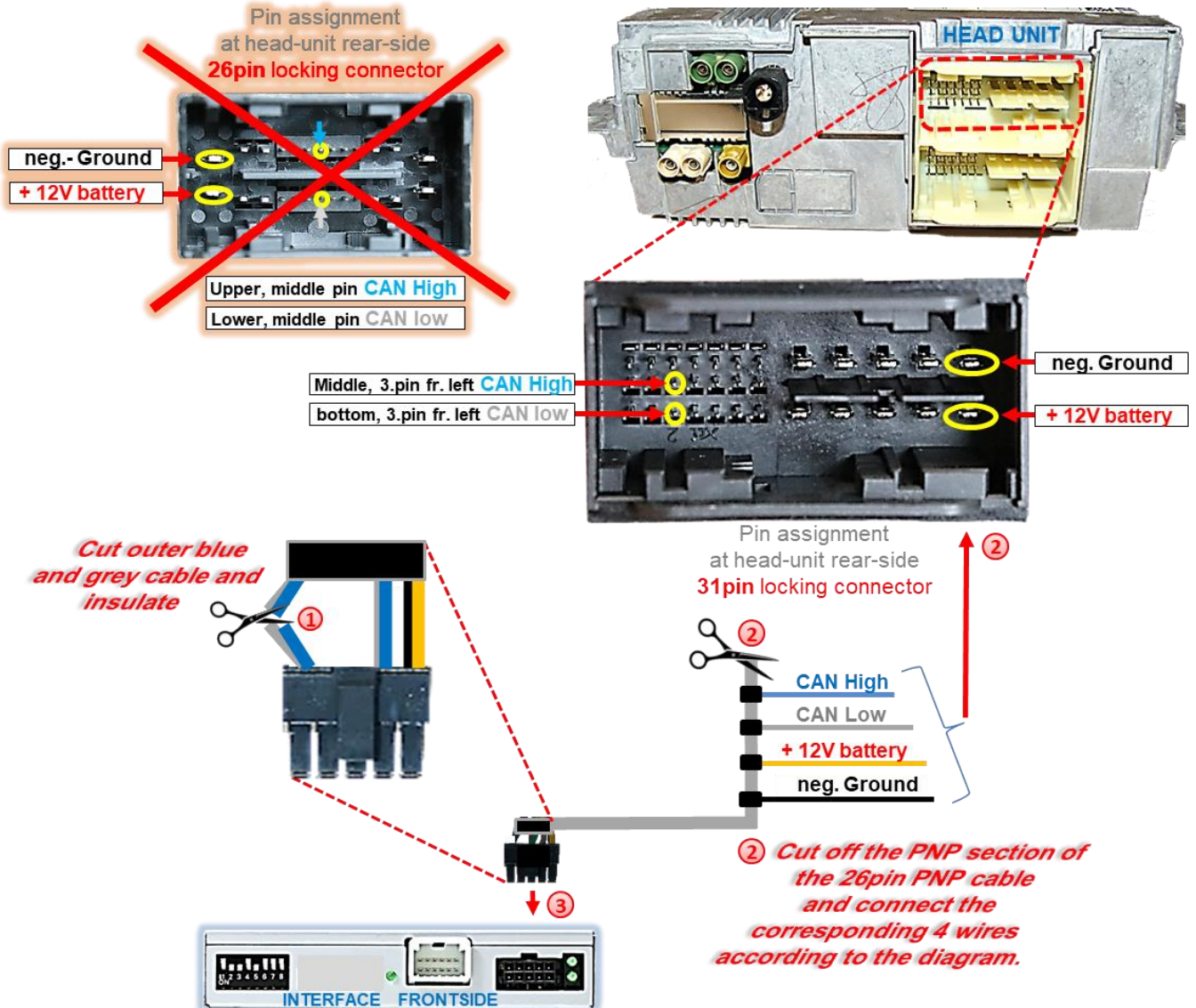

- 1 Cut the outer blue and grey wires of the 26pin PNP cable at the 10-pin connector and insulate all cable ends.
- 2 Cut the PNP section of the 26pin PNP cable, expose the CAN and power cables of the remaining 10pin harness and connect them to the factory wiring harness, according to the diagram above.

Caution: The blue and grey coloured cables, previously disconnected at the 10-pin connector, must not be connected and are to be ignored (do not mix them up)!

- 3 Connect the 10-pin socket of the laid-on lines to the 10-pin plug of the video interface.

2.4.3 Connection - 26pin PNP cable (analogue without CAN-bus)

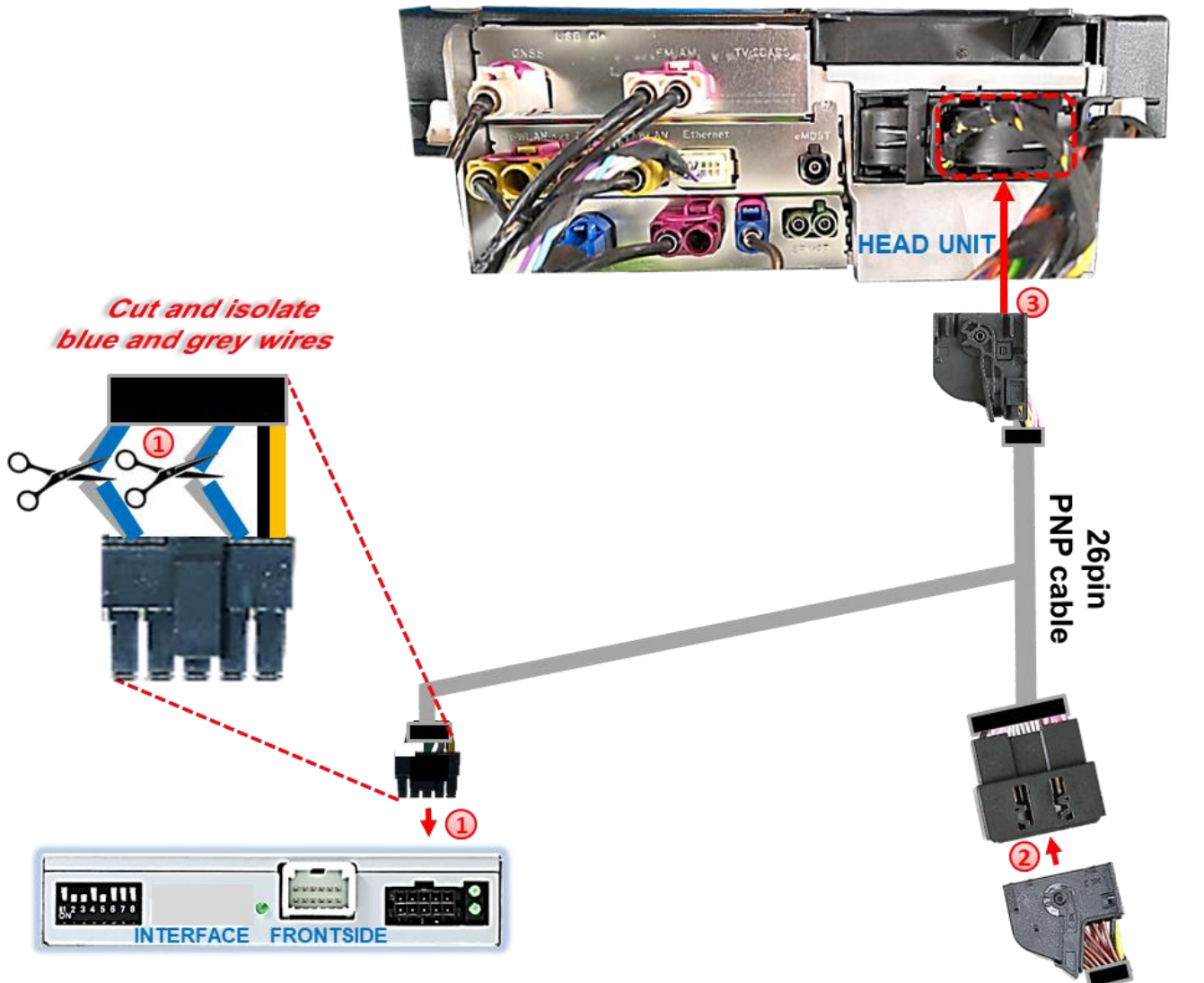

- ① Cut all the blue and grey wires of the enclosed 26-pin PNP cable close to the 10-pin connector and insulate all 8 cable ends.
- ② Connect the enclosed 26pin PNP cable's female 10pin connector to the male 10pin connector of the video interface.
- ③ Disconnect the female 26pin connector of the factory harness at the rear-side of the head-unit and connect it to the male 26pin connector of the enclosed 26pin PNP cable.
- ④ Connect the opposite female 26pin connector of the enclosed 26pin PNP cable to the previously become free male 26pin connector of the factory head-unit.



Attention: For analogue connection (without CAN bus), the violet wire of the 12-pin interface cable must also be connected to +12V or +24V ACC accessory power (see chapter „Connection – switching input by 12pin interface cable (with analogue connection without CAN-Bus)“).

2.4.3.1 Connection – switching input by 12pin Power cable (with analogue connection without CAN-Bus)

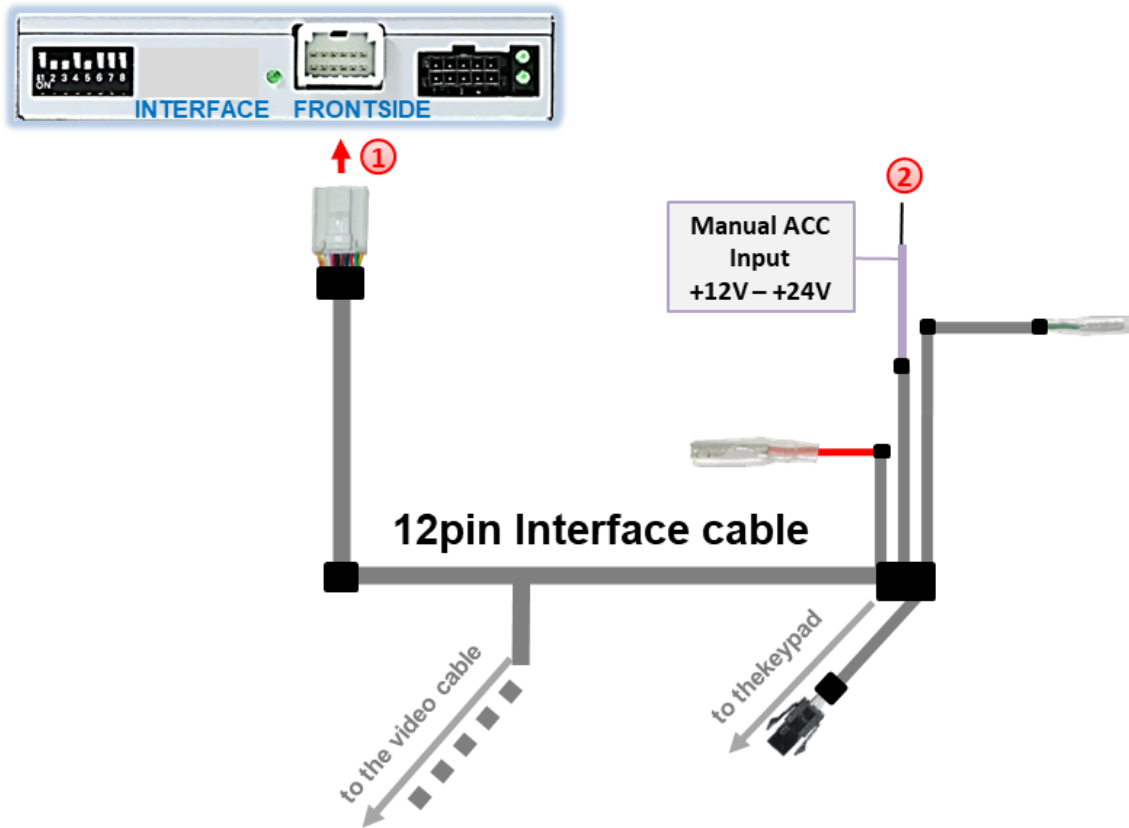

- 1 Connect the enclosed 12pin interface cable's female 12pin connector to the male 12pin connector of the video interface.
- 2 Connect the purple coloured wire „**Manual ACC Input +12V - +24V**“ of the 12pin interface cable to **S-contact terminal 86s** e.g. glove compartment illumination (Connection to ACC Accessory power not sufficient).

Note:



Only as long as the video interface is switched on via +12V by the 10pin connector of the 26pin PNP cable and via +12V - +24V by the purple wire „**Manual ACC Input +12V - +24V**“ of the 12pin interface cable, the infotainment screen is also switched on.

Otherwise, the factory picture is black.

When selecting the switch signal, please check whether the factory picture is available in all desired operating states.

2.5. Connection – reverse signal (analogue)

Tapping the reverse signal Mercedes Actros 5

White 52pin. connector (**A7X2**) at ASAM position X2
Pin52 (cable colour probably purple/blue)

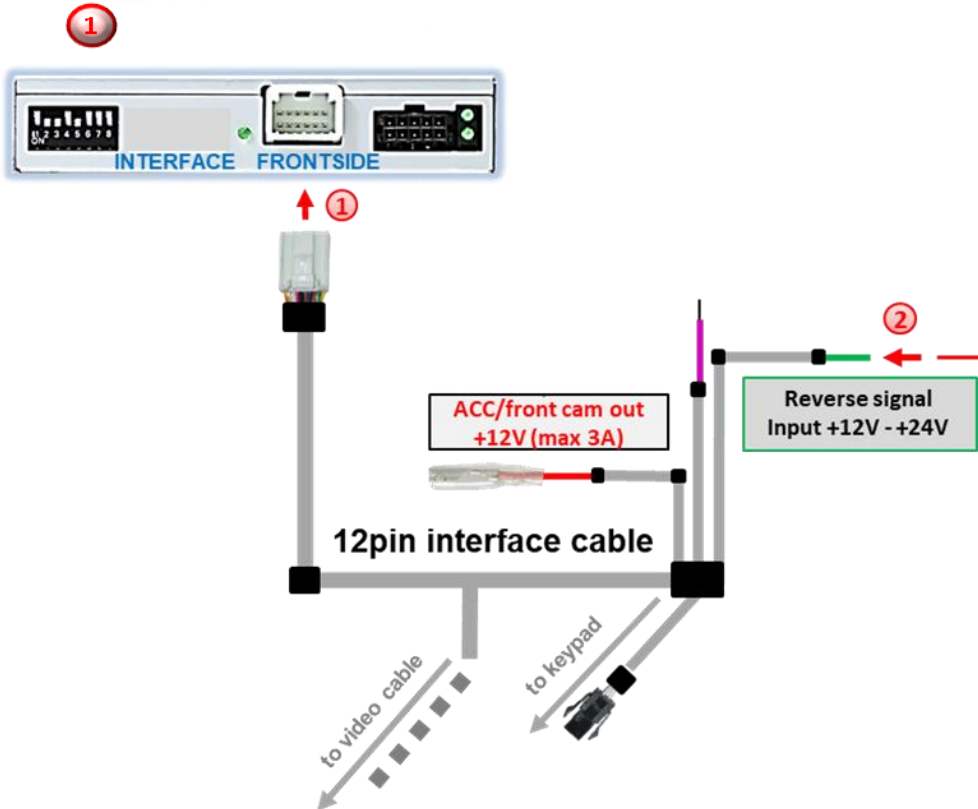
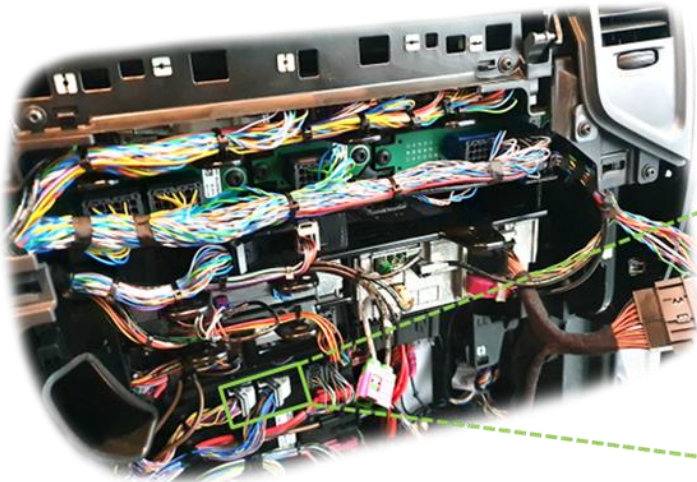

- 1 Connect the green switch input cable "Reverse-signal input +12V - +24V" of the 12-pin interface cable to the according revers light power pin of the vehicle.

Note: To tap the reversing signal, the 52pin connector **A7X2** is located near the head unit. The 24V reverse signal is located on **pin52** of this connector.

2.6. Power-Supply - After-market rear-view camera and after-market front camera

The red power supply output **ACC/front cam out 12V (max 3A)** can be used to power up the cameras. If Dip 1 is set to ON (of the black 8 dips), the power supply output supplies +12V (max 3A) for the rear-view camera when the reverse gear is engaged, and additionally 10 seconds delay for a front camera after the reverse gear is disengaged.

Note: In addition, a manual switch-over to the front camera input is possible via keypad (short press) from any image mode. The power supply output supplies +12V then, too (if Dip 1 is set to ON and the front camera input is selected).

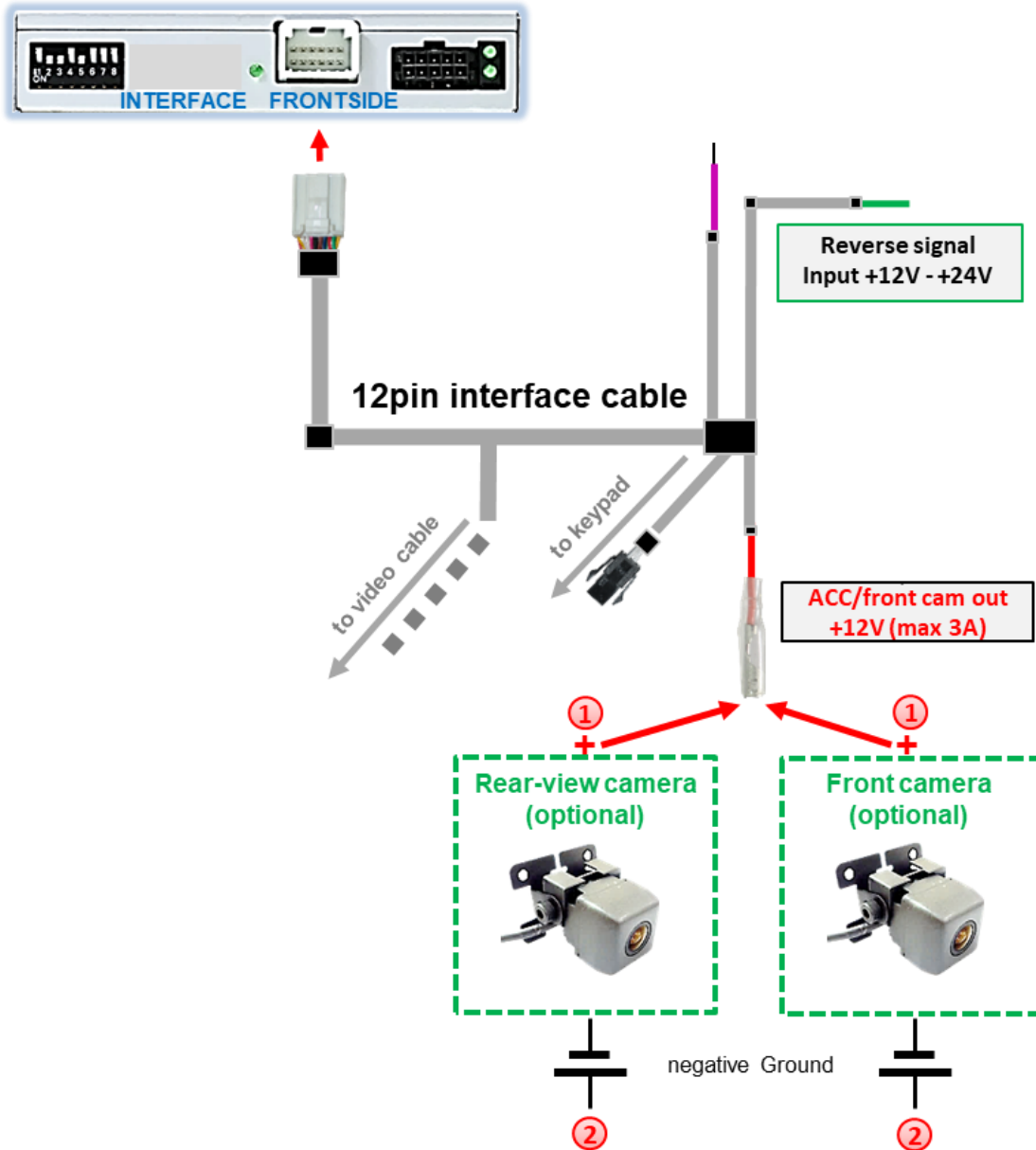

- ① Connect the rear-view camera power cable to the red wire "**ACC/front cam out +12V (max 3 A)**" of the 12-pin interface cable.
- ② Connect the negative cable of the front camera to the vehicle's negative Ground.

2.7. Power supply output

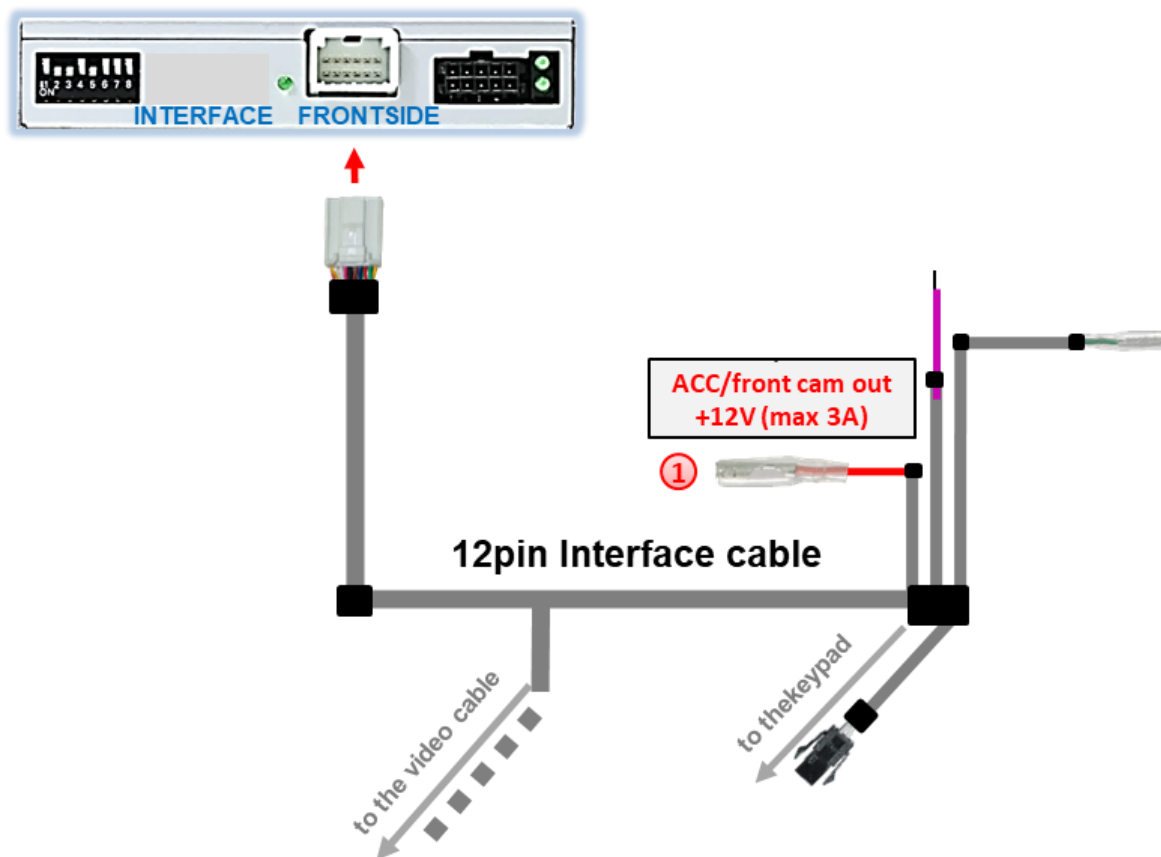

① The red power supply output **ACC/front cam out 12V (max 3A)** can alternatively be used to power an external source and has a different assignment depending on the position of dip switch 1 (of the black 8 dips):

Dip	Function
Dip 1 ON	+12V (max. 3A) when reverse gear is engaged incl. 10 seconds delay after reverse gear is disengaged and +12V by manual switching to front camera by keypad (short press)
Dip 1 OFF	+12V (max. 3A) simulated ACC

2.8. Connection - video-interface and external keypad

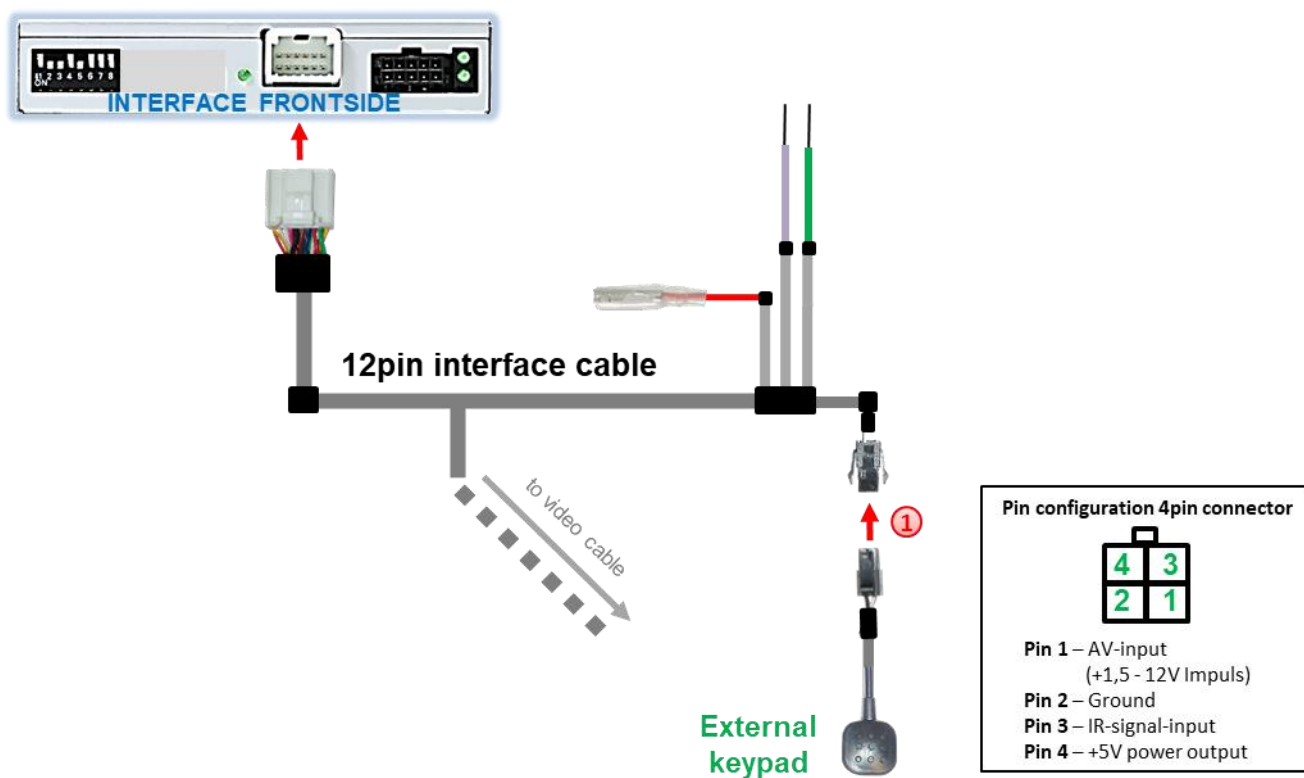

- 1 Connect the female 4pin connector of the keypad to the male 4pin connector of the 12pin interface cable.

Note: Even if switching through several video sources by the keypad mightn't be required, for support events the connection and reachable availability is strongly recommended.

2.9. Connection - video sources

It is possible to connect an after-market rear-view camera, an after-market front camera and two more video sources to the video-interface.

Before a final installation of the video sources, we recommend a test-run to ensure the compatibility of vehicle and interface. Due to changes in the production of the vehicle manufacturer there's always a possibility of incompatibility.

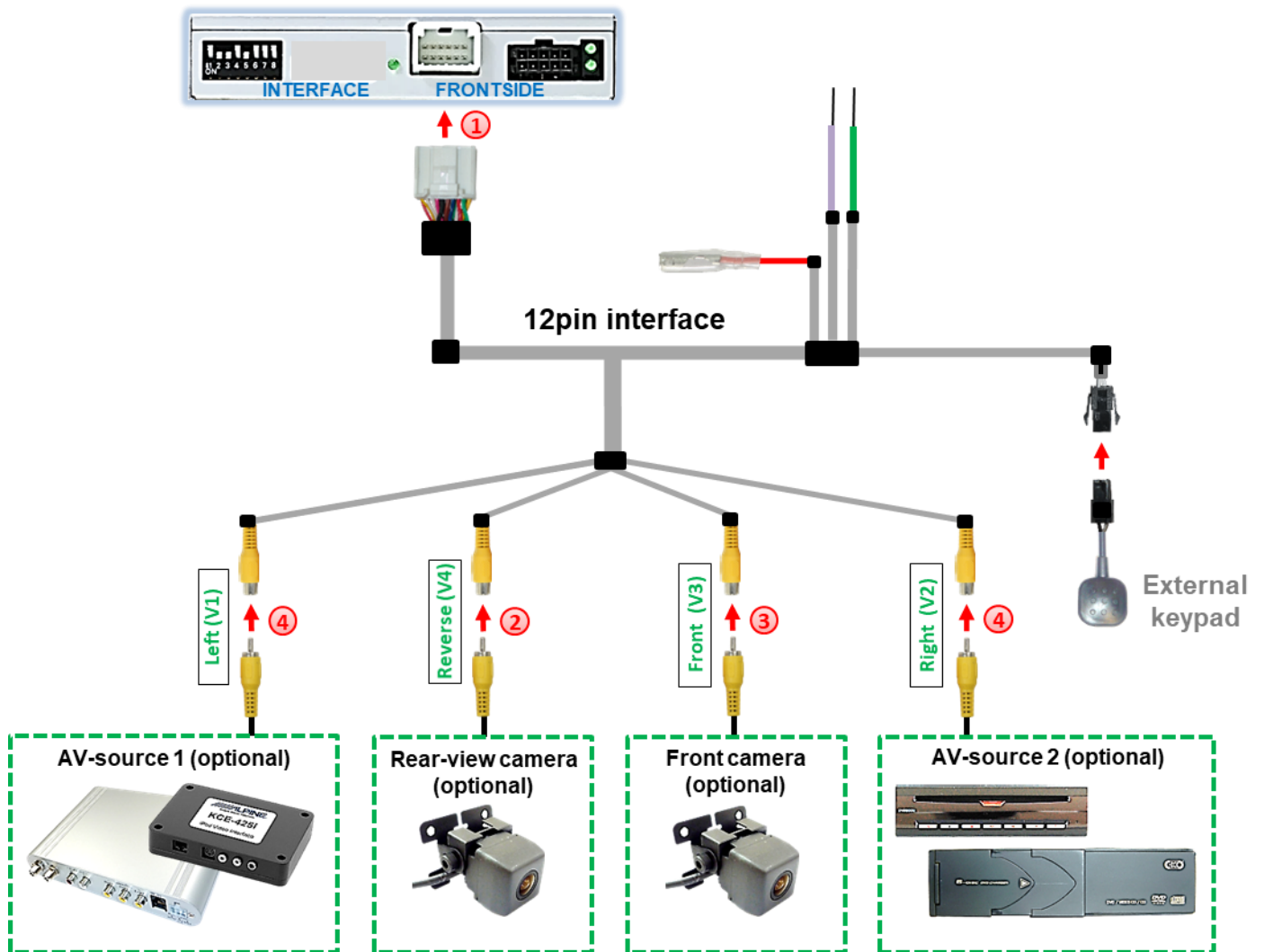

- ① Connect the 12pin interface cable's female 12pin connector to the male 12pin connector of the video-interface.
- ② Connect the video RCA of the Rear-view camera to the 12pin interface cable's female RCA connector „Reverse V4“.
- ③ Connect the front camera's video RCA connector to the 12pin interface cable's female RCA connector „Front V3“.
- ④ Connect the video RCA of the AV source 1 and 2 to the 12pin interface cable's female RCA connector “Left (V1)” and “Right (V2)”.

2.10. Audio-insertion

This interface is only able to insert video signals into the factory infotainment. If an AV-source is connected, the audio insertion has to be done by the factory audio AUX input or an FM-modulator. The inserted video-signal can be activated simultaneously to each audio-mode of the factory infotainment. If 2 AV sources shall be connected to the infotainment, additional electronic is necessary to switch the audio signals.

2.11. Picture settings

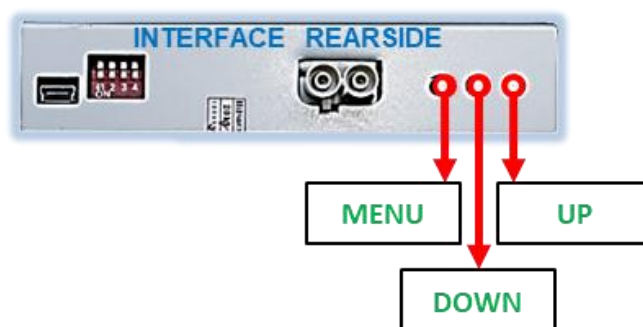

The picture settings are adjustable by the 3 push-buttons at the rear-side of the video-interface. Press the MENU button to open the OSD settings menu or to switch to the next menu item. Press UP and DOWN to change the selected value. The buttons are placed inside in the housing to avoid accidental changes during or after the installation. Picture settings must be done separately for all video inputs while the corresponding input is selected and visible on the monitor.

Note: The OSD menu is only shown when a working video source is connected to the selected video-input of the interface.

The following settings are available:

➤ **Version with 6-dip switches on the top of the housing**

- Contrast
- Brightness
- Saturation
- Position H (horizontal picture position)
- Position V (vertical picture position)
- IR-AV1/2 (no function)
- Guide L (no function)
- Guide R (no function)
- UI-CNTRL (no function)
- Size H/V (horizontal picture size)
- Size V (vertical picture size)

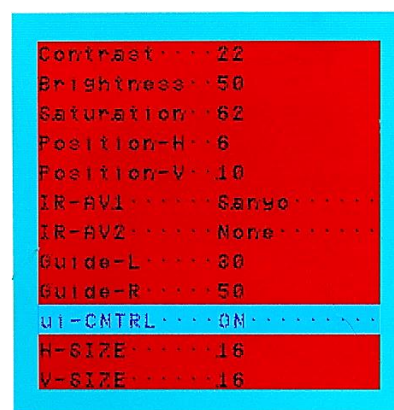

➤ Version **without** 6-dip switches on the top of the housing

Contrast
Brightness
Saturation
Position H = horizontal picture position
Position V = vertical picture position
Guide-Pos = no function
Size H = horizontal picture size
Size V = vertical picture size

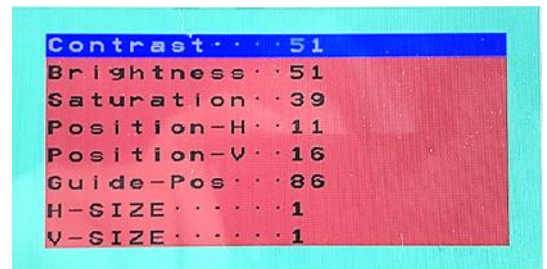

3. Interface operation

The external keypad can be used to switch the activated inputs.

➤ Long press of keypad (2-3 seconds)

By long pressing the external keypad (2-3 seconds), the video interfaces switches the input from the factory video to the inserted video sources. If all inputs are activated by dip switch settings, the order is the following:

Factory video → Left (V1) → Right (V2) → factory video

Each long press will switch to the next enabled input. Inputs which are not enabled will be skipped.

Note: The interface switches after releasing the switch (after long pressure).

➤ Short press of keypad (only if DIP 1 is set to ON)

By short pressing the external keypad, the video interfaces switches from the factory video to the front camera input and with press-repeat back to factory video.

4. Specifications

BATT/ACC range	7V - 25V
Stand-by power drain	8mA
Power	260mA @12V
Video input	0.7V - 1V
Video input formats	NTSC
Temperature range	-40°C to +85°C
Dimensions video-box	119 x 24 x 100 mm (W x H x D)

5. FAQ – Trouble shooting Interface functions

For any troubles which may occur, check the following table for a solution before requesting support from your vendor.

Symptom	Reason	Possible solution
No picture/black picture (factory picture).	Not all connectors have been reconnected to factory head-unit or monitor after installation.	Connect missing connectors.
	No power on CAN-bus box (all LED CAN-bus box are off).	Check power supply of CAN-bus box. Check CAN-bus connection of CAN-bus box.
	CAN-bus box connected to CAN-bus in wrong place.	Refer to the manual where to connected to the CAN-bus. If not mentioned, try another place to connect to the CAN-bus.
	No power on video-interface (all LED video-interface are off).	Check whether CAN-bus box delivers +12V ACC on red wire output of 8pin to 6pin cable. If not cut wire and supply ACC +12V directly to video-interface.
No picture/black picture/white picture (inserted picture) but factory picture is OK.	No picture from video source.	Check on other monitor whether video source is OK.
	No video-source connected to the selected interface input.	Check settings dips 1 to 3 of video interface which inputs are activated and switch to corresponding input(s).
	LVDS cables plugged in wrong place.	Double-check whether order of LVDS cables is exactly connected according to manual. Plugging into head-unit does not work when the manual says to plug into monitor and vice versa.
Inserted picture totally wrong size or position.	Wrong monitor settings of video-interface.	Try different combinations of dips 7 and 8 of video-interface. Unplug 6pin power after each change.
Inserted picture double or 4 times on monitor.		
Inserted picture distorted, flickering or running vertically.	Video sources output set to AUTO or MULTI which causes a conflict with the interfaces auto detection.	Set video source output fixed to PAL or NTSC. It is best to set all video sources to the same standard.
	If error occurs only after source switching: Connected sources are not set to the same TV standard.	Set all video sources to the same standard.
	Some interfaces can only handle NTSC input.	Check manual whether there is a limitation to NTSC mentioned. If yes, set source fixed to NTSC output.
Inserted picture b/w.	Picture settings have not been adjusted.	Use the 3 buttons and the interface's OSD to adjust the picture settings for the corresponding video input.
Inserted picture qual. bad.		
Inserted picture size slightly wrong.		
Inserted picture position wrong.		
Camera input picture flickers.	Camera is being tested under fluorescent light which shines directly into the camera.	Test camera under natural light outside the garage.
Camera input picture is bluish.	Protection sticker not removed from camera lens.	Remove protection sticker from lens.

Symptom	Reason	Possible solution
Camera input picture black.	Camera power taken directly from reverse gear lamp.	Use relay or electronics to "clean" reverse gear lamp power. Alternatively, if CAN-bus box is compatible with the vehicle, camera power can be taken from green wire of 6pin to 8pin cable.
Camera input picture has distortion.		
Camera input picture settings cannot be adjusted.	Camera input picture settings can only be adjusted in AV2 mode.	Set dip 3 of video-interface to ON (if not input AV2 is not already activated) and connect the camera to AV2. Switch to AV2 and adjust settings. Reconnect camera to camera input and deactivate AV2 if not used for other source.
Graphics of a car in camera input picture.	Function PDC is ON in the interface OSD.	In compatible vehicles, the graphics will display the factory PDC distance. If not working or not wanted, set interface OSD menu item UI-CNTRL to ALLOFF.
Chinese signs in camera input picture	Function RET or ALL is ON (function for Asian market) in the interface OSD.	Set interface OSD menu item UI-CNTRL to ALLOFF or PDCON.
Not possible to switch video sources by OEM button.	CAN-bus interface does not support this function for vehicle.	Use external keypad or cut white wire of 6pin to 8pin cable and apply +12V impulses for AV-switching.
Not possible to switch video sources by external keypad.	Pressed too short.	For video source switching a longer press of about 2.5 seconds is required.
	SW-version of interface does not support external keypad.	Use OEM-button or cut white wire of 6pin to 8pin cable and apply +12V impulses for AV-switching.
Interface does not switch to camera input when reverse gear is engaged.	CAN-bus interface does not support this function for the vehicles.	Cut the green wire of the 6pin to 8pin cable and apply +12V constant from reverse gear-lamp signal. Use relay to "clean" R-gear lamp power.
Interface switches video-sources by itself.	CAN-bus interface compatibility to vehicle is limited.	Cut the grey wire of 6pin to 8pin and isolate both ends. If problem still occurs, additionally cut the white wire of 6pin to 8pin cable and isolate both ends.



10R-05 0068

Made in China

