



Audi TT 2008-2015

KIT FEATURES

- ISO DDIN radio provision
- Painted scratch resistant matte black
- Location to retain the factory passenger airbag light

KIT COMPONENTS

- A) Radio trim panel • B) Radio housing • C) (4) Panel clips • D) (8) ISO screws

A

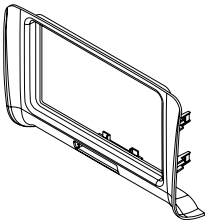

B

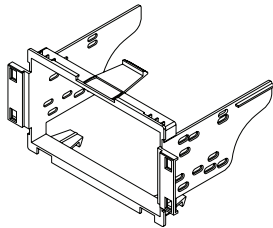

C

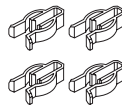

D

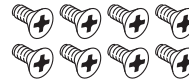

TABLE OF CONTENTS

| | |
|------------------------|---|
| Dash Disassembly | 2 |
| Kit Assembly | 3 |

TOOLS REQUIRED

- Panel removal tool • Phillips screwdriver
- Socket wrench

Attention! Let the vehicle sit with the key out of the ignition for a few minutes before removing the factory radio. When testing the aftermarket equipment, ensure that all factory equipment is connected before cycling the key to ignition.

DASH DISASSEMBLY

1. Insert removal tools into the slots on the front of the radio face, and then remove the radio. (Figure A)
2. Unplug airbag light, then unsnap and remove from the factory radio.

Continue to Kit Assembly

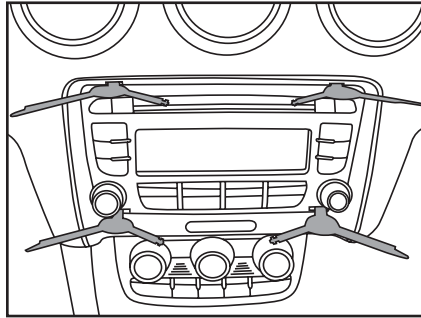

(Figure A)

KIT ASSEMBLY

ISO DDIN radio provision

1. Attach the (4) supplied **panel clips** to the **radio trim panel**. (Figure A)
2. Attach the **radio housing** to the radio using screws supplied with the radio. (Figure B)

Note: The radio mounting screws must be flush in the brackets so the radio assembly will fit into the dash opening. Screws have been provided in the event they were not provided with the aftermarket radio.

3. Locate the factory wiring harness and antenna connector in the dash, and complete all necessary connections to the radio.
4. Slide the radio/radio housing assembly into the dash opening paying close attention to the guides on the **radio housing** and the slots in the dash opening.

Note: Be sure to keep the passenger airbag light plug accessible while mounting the radio into the dash.

5. Snap the **radio trim panel** over the radio and reassemble the dash in reverse order of disassembly.

Note: Snap the factory airbag light in from the front, then plug the airbag light in while snapping the **radio trim panel** over the radio.

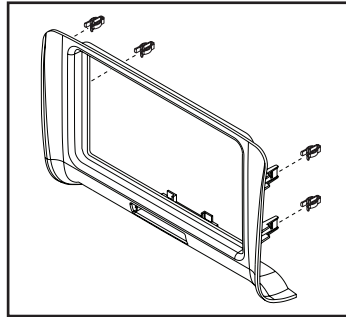

(Figure A)

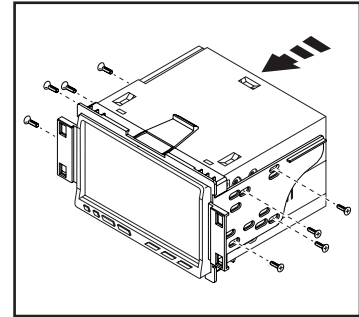

(Figure B)