



Vehicle Application

Volvo C30 (P14) 2007–2013 (Hatchback)

Volvo S40 II (P11) 2004–2012 (Saloon)

Volvo V50 (P12) 2004–2012 (Estate)

Volvo C70 II (P15) 2006–2013

KEY FEATURES

- This fascia kit allows the installation of an aftermarket head unit into a non din sized aperture
- High quality finish designed to match the vehicle dashboard
- Fascia kit supplied with mounting bracket

The information provided in this document is subject to change without notice due to changes and/or improvements to the product/s.

PRIOR TO INSTALLATION

Read the manual prior to installation. Technical knowledge is necessary for installation. The place of installation must be free of moisture and away from heat sources. Please ensure that the correct tools are using during the installation to avoid damage to the vehicle or product.

InCarTec can not be held responsible for the installation of this product.

INSTALLING THE FACIA (PART 1)

1. Use a panel removal tool to carefully remove the OEM radio and centre panel of the car.

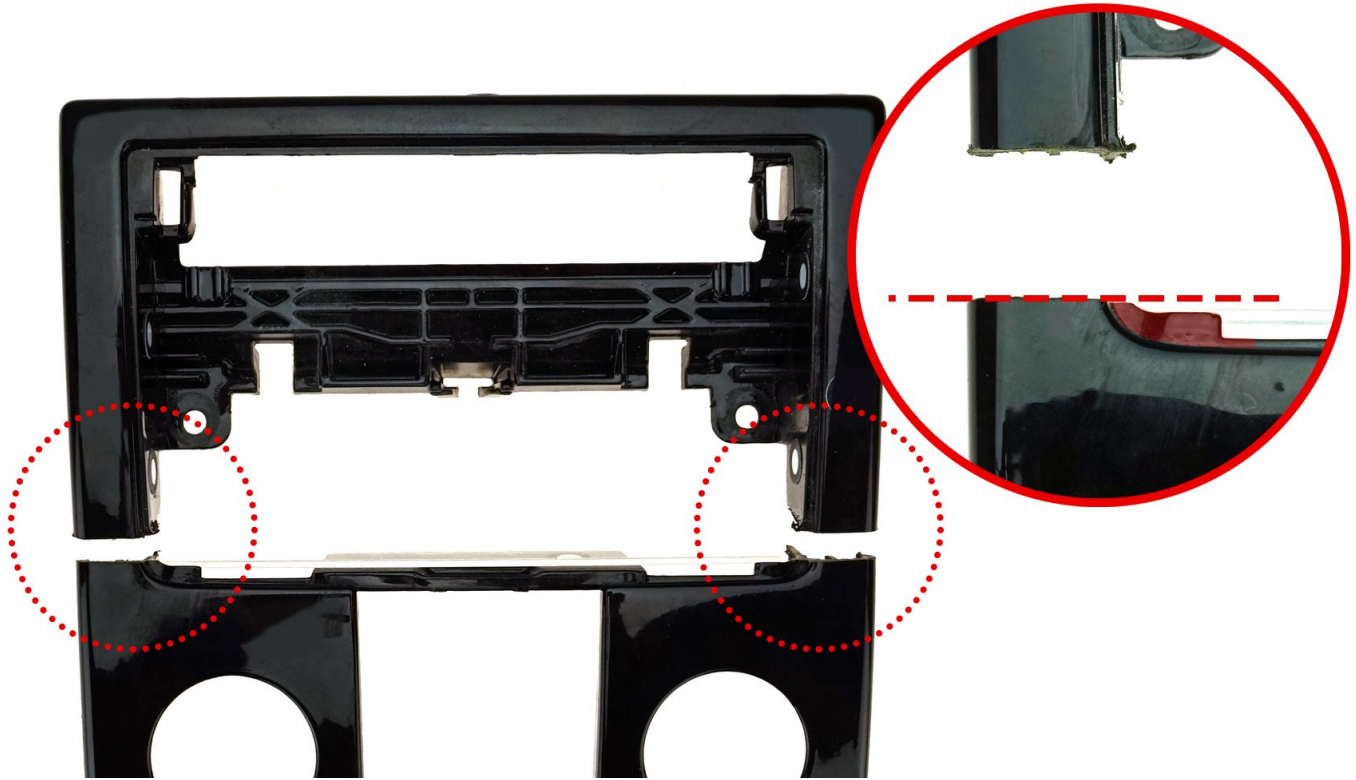

2. **The original panel will need to be cut. See highlighted section.** Cut the centre panel in line with the highlighted tab just above the bottom of the opening on each side.

The aftermarket fascia panel will cover the cut marks however please do this as straight and neat as possible.

ASSEMBLY DIAGRAM

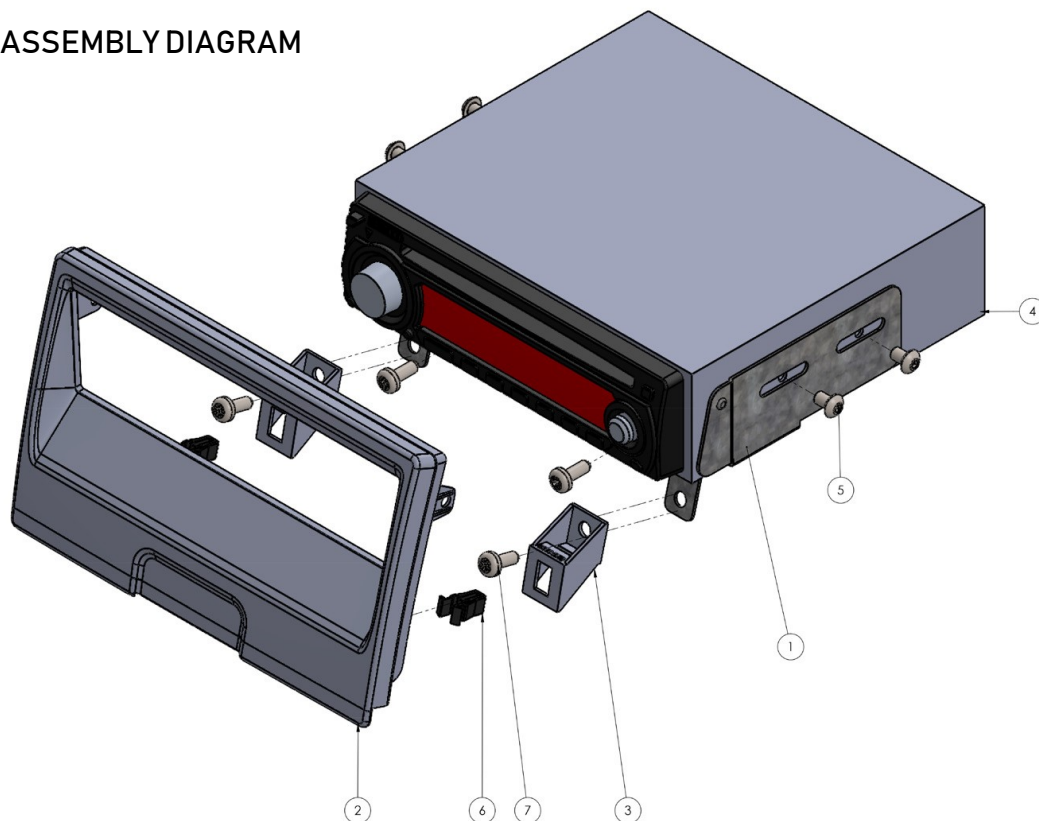

1. Bracket
2. Fascia Panel
3. Clip Mount
4. Aftermarket Radio
5. Supplied M5 x 8 (x4)
6. Plastic Clip
7. OEM screws (re-use)

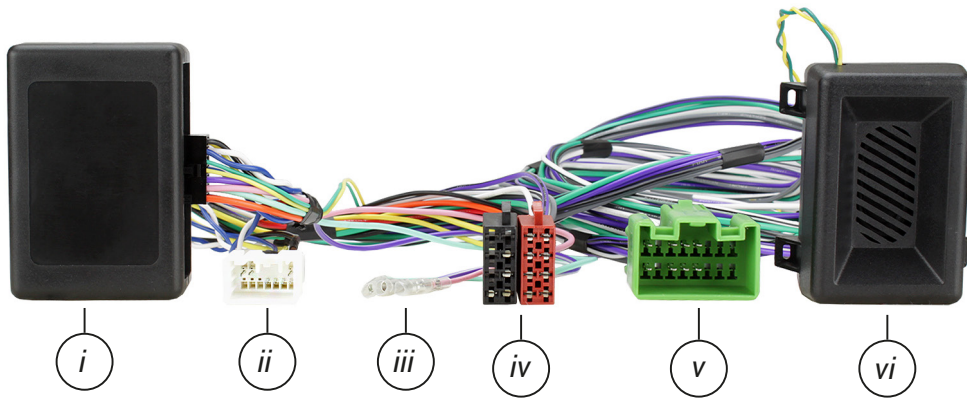

- i. Interface Box
- ii. Vehicle Specific Power Connector
- iii. Additional Wiring Outputs
- iv. ISO Power/Speaker Connector
- v. Volvo Amplifier Connector
- vi. Speaker Module

WIRING CONNECTIONS

IN ISO CONNECTOR

Purple	Right Rear Speaker +	Yellow	Permanent 12V
Purple/Black	Right Rear Speaker -	Black	Ground
Green	Left Rear Speaker +	Red	Ignition 12V
Green/Black	Left Rear Speaker -	Orange	Illumination
Grey	Right Front Speaker +		
Grey/Black	Right Front Speaker -		
White	Left Front Speaker +		
White/Black	Left Front Speaker -		

ADDITIONAL CONNECTIONS

Pink	Speed Pulse
Green	Park Brake
Purple/White	Reverse Gear

STEERING WHEEL CONTROL FUNCTIONS

The following diagram, though based on careful research, is an example only. Individual steering wheel control configurations may differ.

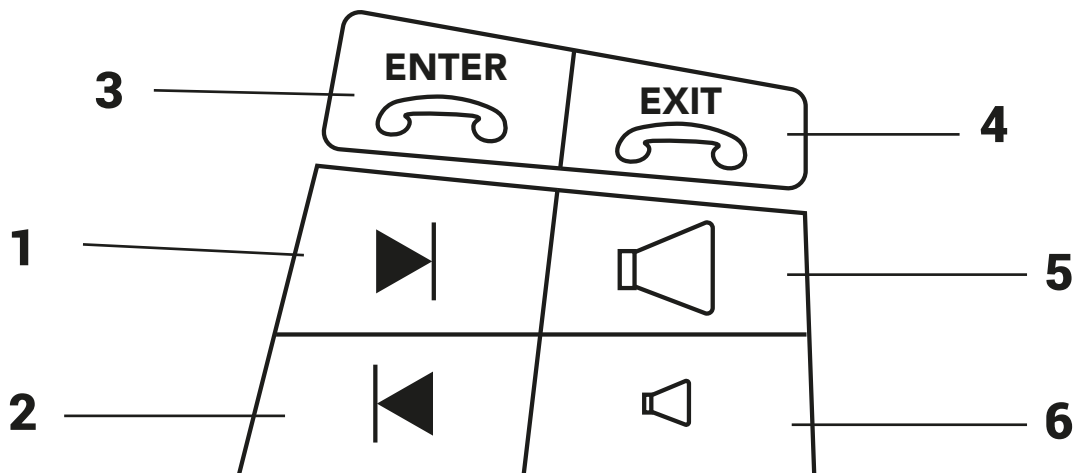

- | | | | |
|------|--------------------|------|------------------|
| 1. | Track Up | 4. | Hang Up |
| 2. | Track Down | 5. | Volume Up |
| 1&2. | Source (Hold Both) | 6. | Volume Down |
| 3. | Pick Up | 5&6. | Mute (Hold Both) |

INSTALLATION DIAGRAM

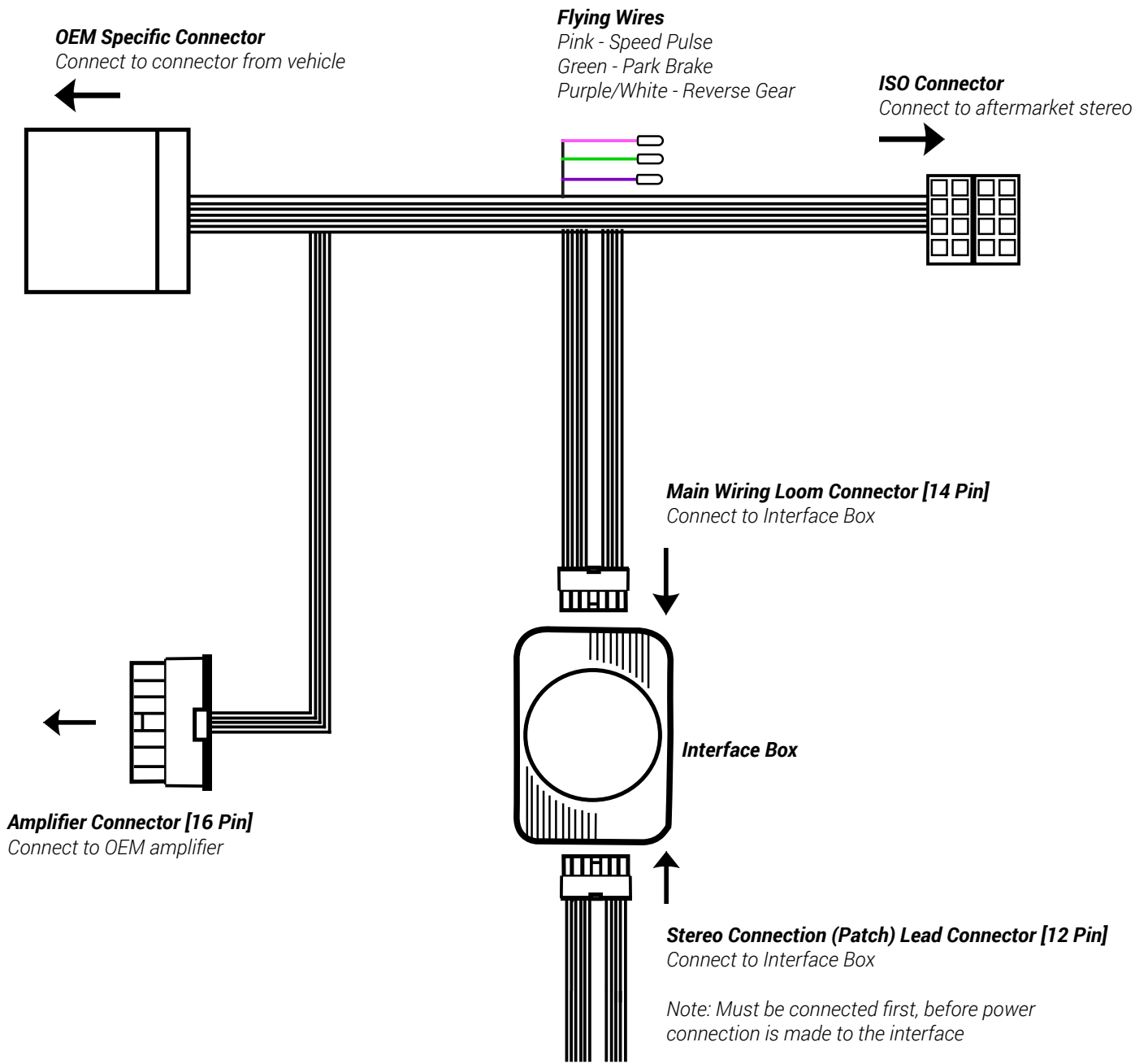

INSTALLING THE INTERFACE

Before installing the interface, the factory stereo must be removed and disconnected. To do this, please consult the vehicle owner's manual/handbook or contact a fitting professional.

A stereo connection (patch) lead is also required for the installation of this interface (supplied separately). Please ensure that you have the correct lead before proceeding. For universal patch leads, prepare the wiring loops in accordance with the instruction manual supplied with the product before installation.

1. Connect the 12 Pin connector from the stereo connection (patch) lead to the interface box
2. Connect the opposite end of the stereo connection (patch) lead to the steering wheel control input on the back of the aftermarket stereo

NOTE: This may be a 3.5mm jack connector or a wired input depending on the brand of aftermarket stereo being fitted. Please consult the aftermarket stereo installation manual for further information on where to make the connection

IMPORTANT: THIS STEP MUST BE COMPLETED BEFORE CONNECTING POWER TO THE INTERFACE. FAILURE TO DO SO MAY RESULT IN A LACK OF FUNCTIONALITY AND THE NEED TO REINSTALL THE PRODUCT

3. Connect the 14 Pin connector from the supplied wiring loom + 2-pin speaker wire to the interface box
4. Connect the power/speaker ISO connector to the power/speaker ISO connector at the rear of the aftermarket stereo

NOTE: For aftermarket stereos which do not have an ISO connector, please see "Wiring Key" on Pg.2 for information on which wires to connect. Some interfaces may also have additional 'flying' wires which can be connected to the vehicle to support various features ie. parking brake trigger, reverse gear and speed pulse. Details of these can be found under 'Additional Connections'.

5. Connect the additional flying wires to the aftermarket head unit's wiring harness as required
6. Connect the Amplifier connector to the vehicles OEM amplifier (for these models, the amplifier is located within the trunk)
7. Connect the vehicle specific power connector on the supplied harness to the OEM connector from the vehicle
8. Test stereo and steering wheel control functionality for correct operation before reassembling the vehicle dashboard. If steering wheel control functions are unresponsive, please uninstall the interface and wiring and reinstall carefully in accordance with the above steps

FACIA INSTALLATION (PART 2)

3. Use supplied M5 x 8 screws (x4) to attach the bracket to the aftermarket stereo.
4. Use OEM screws to secure the bracket and stereo into the open dash of the vehicle.
5. Use the supplied clip mounts (x2) and OEM screws to secure into the open dash of the vehicle as pictured below.

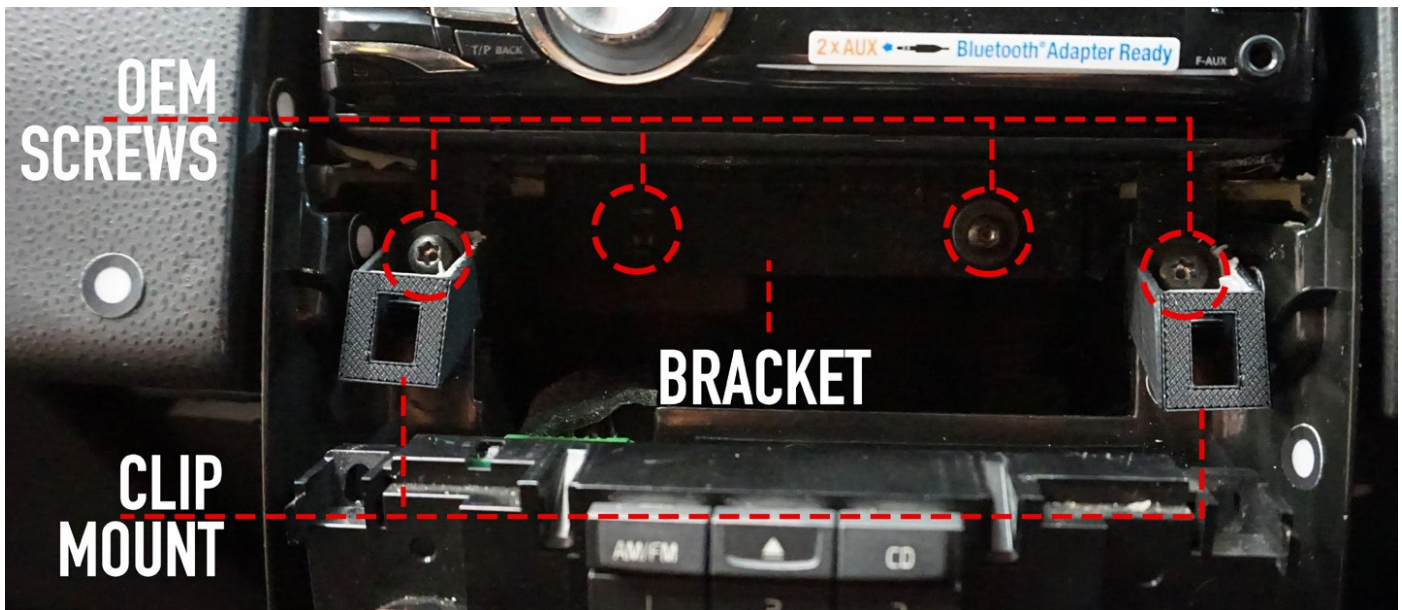

6. Re install OEM centre console panel.
7. Attach clips to fascia panel as pictured in assembly diagram.
8. Push fascia panel in to place. Fascia panel should clip into place, lining up clips in to clip mount brackets. Fascia lip will cover cut OEM centre panel as pictured below.

