

50-762 INSTALLATION INSTRUCTIONS

APPLICATIONS

LEXUS GS 300/400

1998-2004

*Not For Use In Vehicles
With Factory Navigation*

KIT FEATURES

- Double DIN Radio Provision
 - Stacked ISO Mount Units Provision
-

KIT COMPONENTS

A) Double DIN Radio Housing B) Double DIN Brackets

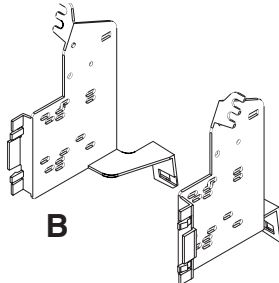
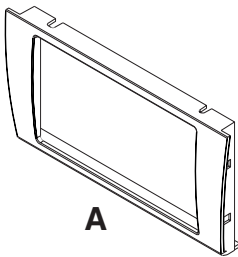

TOOLS REQUIRED:

Small Flat Blade Screwdriver/ Panel Removal Tool

- Phillips Screwdriver



TABLE OF CONTENTS

Dash Disassembly

- Lexus GS 300/400 1998-2005 1,2

Kit Assembly

- Double DIN Radio Provision ... 3

- Stacked ISO Mount Units Provision 3

Final Assembly 4

***Note:**

Refer also to the instructions included with the aftermarket radio.

LEXUS GS 300/400 1998-2005

- 1** Disconnect the negative battery terminal to prevent an accidental short circuit.
- 2** Unsnap and remove vent/clock assembly from above climate controls. (Figure A)
- 3** Remove two screws from behind vent/clock assembly. (Figure B)
- 4** Unsnap and remove ashtray assembly from below radio. (Figure C)

Continued on next page.

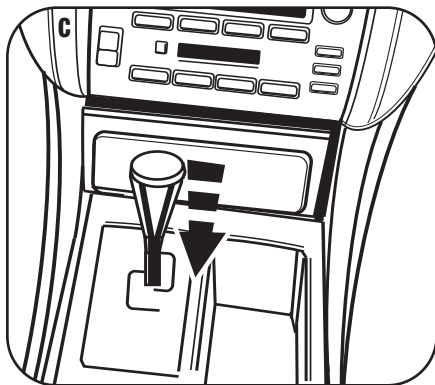
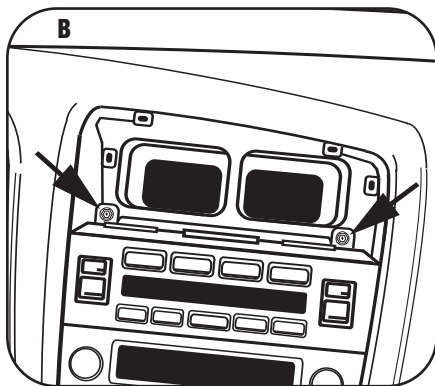
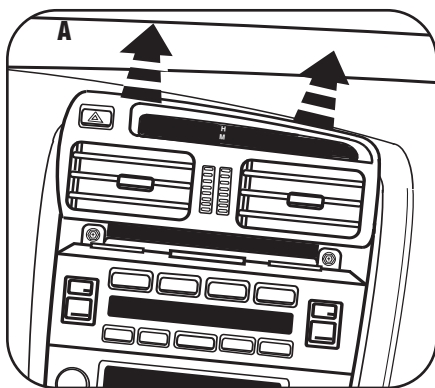

LEXUS GS 300/400 1998-2005

5 Remove (2) screws from behind ash-tray assembly. (Figure D)

6 Unplug and remove radio/climate controls assembly. (Figure E)

7 Remove side brackets to separate the radio from the climate controls. (Retain the climate controls for reuse during kit assembly.) (Figure F)

Continue to kit assembly.

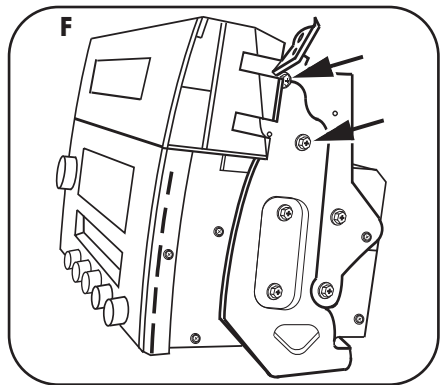
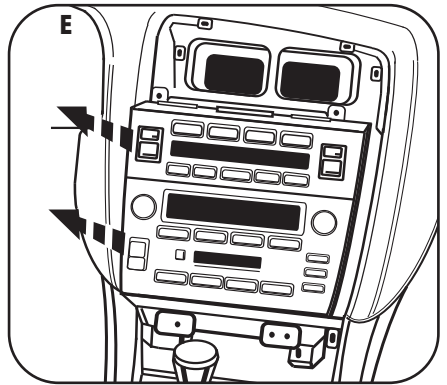
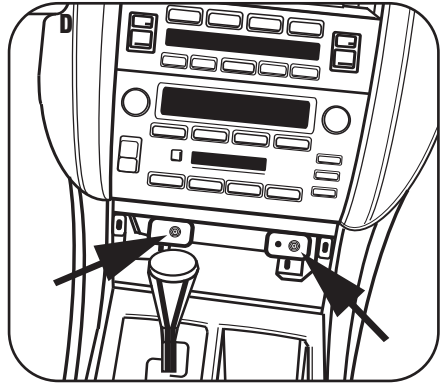

LEXUS GS 300/400 1998-2005

DOUBLE DIN RADIO

STACKED ISO MOUNT UNITS PROVISION

Note: Refer also to the instructions included with the aftermarket radio.

- 1** Snap the Double DIN Brackets onto the Double DIN Radio Housing. (Figure A)
- 2** Slide the factory climate controls into the Bracket/Radio Housing assembly aligning the top of the assembly with alignment pins in the bottom of the climate controls and secure using the factory hardware. (Figure B)
- 3** Slide the Double DIN or stacked ISO mount units into the bracket/radio housing assembly and secure the Double DIN or stacked ISO mount units to the assembly using the screws supplied with the Double DIN or stacked ISO mount units. (Figure C)

Continue to final assembly.

A

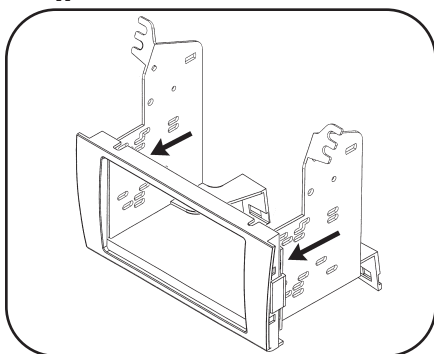

B

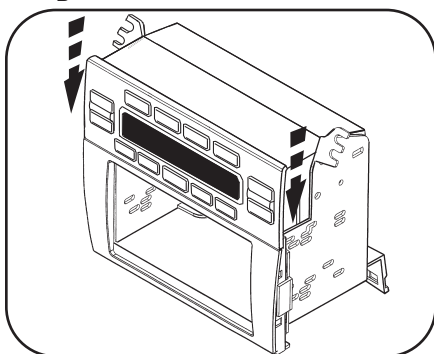

C

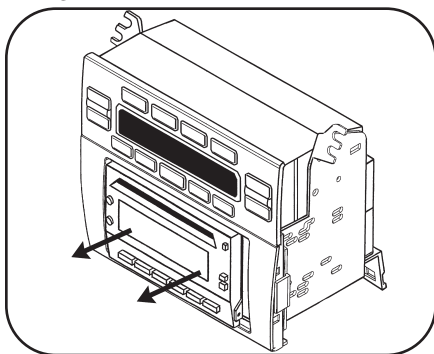

FINAL ASSEMBLY

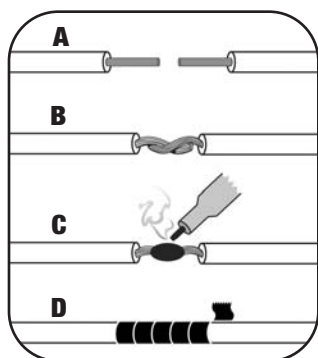

(A) Strip wire ends back 1/2"

B) Twist ends together

C) Solder

D) Tape

- 1 Locate the factory wiring harness in the dash. Metra recommends using the proper mating adapter and making connections as shown. (Isolate and individually tape off the ends of any unused wires to prevent electrical short circuit.)
- 2 Re-connect the negative battery terminal and test the unit for proper operation.
- 3 Reassemble radio and dash assemblies in reverse order of disassembly.

FINAL WIRING CONNECTIONS

Make wiring connections using the EIA color code chart shown below and the instructions included with the head unit. Metra recommends making connections as shown below; Strip, Splice, Solder, Tape. Isolate and individually tape off ends of any unused wires to prevent electrical short circuit.

METRA / EIA WIRING CODE

12V Ignition / Acc. Red	Right Front (+) Gray
12V Batt / Memory. Yellow	Right Front (-). Gray/ Black
Ground. Black*	Left Front (+) White
Power Antenna. Blue	Left Front (-). White / Black
Amp Turn-On Blue / White	Right Rear (+) Violet
Amp Ground. Black / White	Right Rear (-). Violet / Black
Illumination Orange	Left Rear (+) Green
Dimmer Orange / White	Left Rear (-). Green / Black

***NOTE:** When a Black wire is not present, ground radio to vehicle chassis.

All colors may not be present on all leads due to manufacturer's specifications.