

Retention camera interface allowing you to retain/ keep the factory OEM fitted reverse view camera on selected Suzuki and Izuzu cars, when replacing with a new aftermarket head unit. This interface is compatible with select touch screen models with a Green 5 Pin connector.

PLEASE NOTE: For Izuzu/Suzuki touch screen Systems only. Please check connections on the OEM radio for compatibility

INSTALLATION DIAGRAM

PLEASE NOTE: The diagram below shows an overview for the installation of this product. Please turn over the page for step by step instructions.

PLEASE NOTE: The following diagrams show how to connect the camera interface in conjunction with our 29-Series steering wheel control interface

THESE ARE SOLD SEPERATELY

PLEASE REFER TO THE MANUFACTURERS INSTRUCTIONS ON HOW TO CONNECT THE STEERING CONTROL INTERFACE.

OEM Connectors from original Izuzu/ Suzuki unit

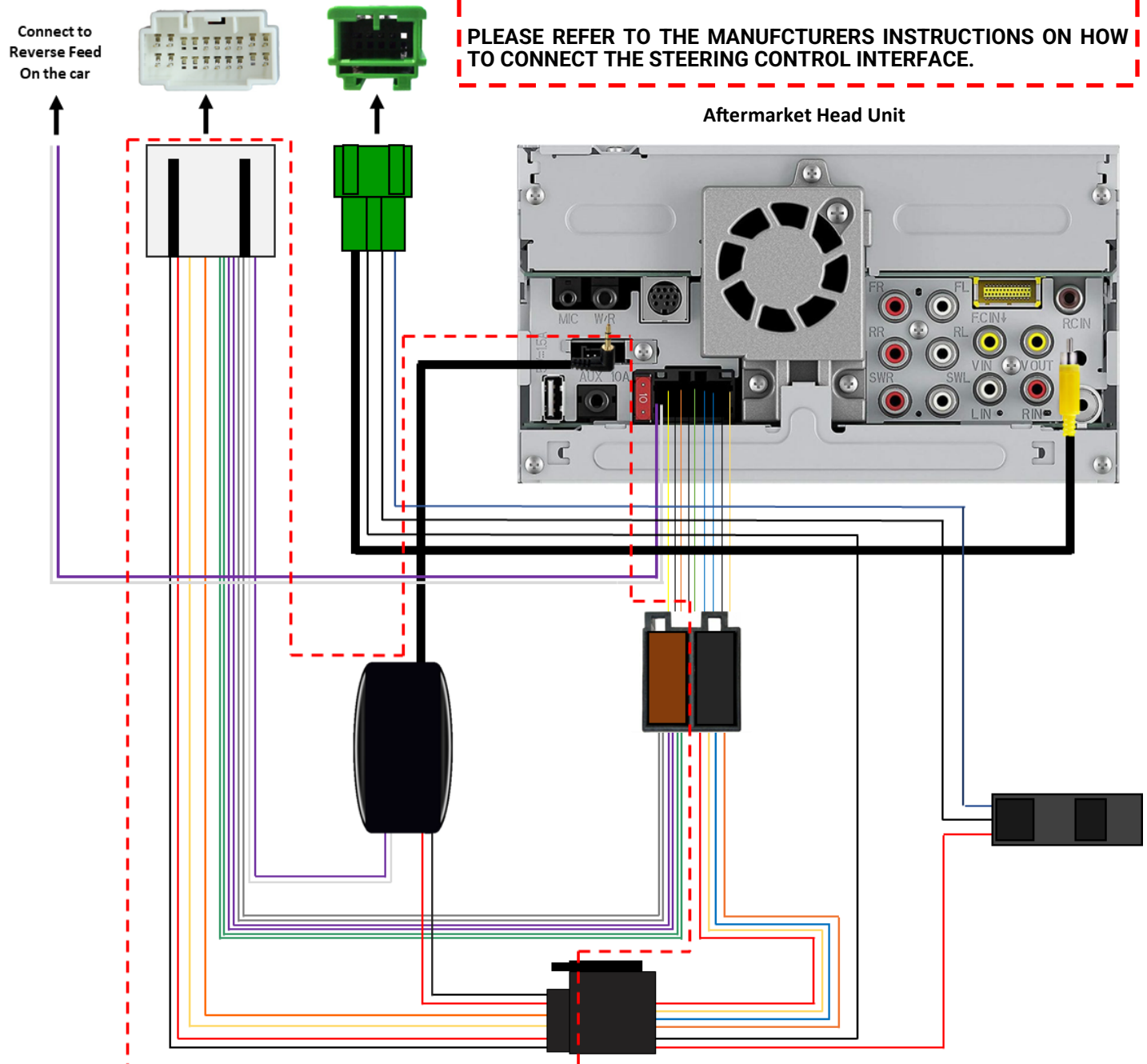

Connect to Reverse Feed On the car

Aftermarket Head Unit

INSTALLING WITH AFTERMARKET SWC INTERFACE

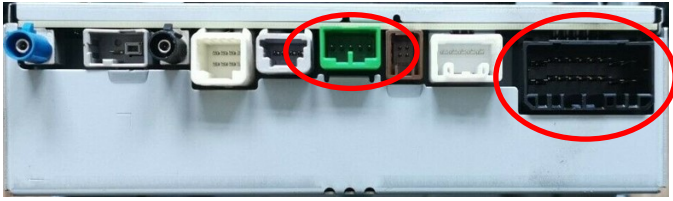

1. Disconnect the original OEM radio from the car. Make a note of the connections highlighted (Left Image)
2. Set up your aftermarket head unit as per the manufacturers instructions
3. Plug in the car specific Steering wheel interface as per the manufacturers instructions.

NOTE: Make sure you leave the Black ISO connector from the steering wheel control interface unplugged, this is used in the next step of the installation.

The installation should be starting to look a little something like this

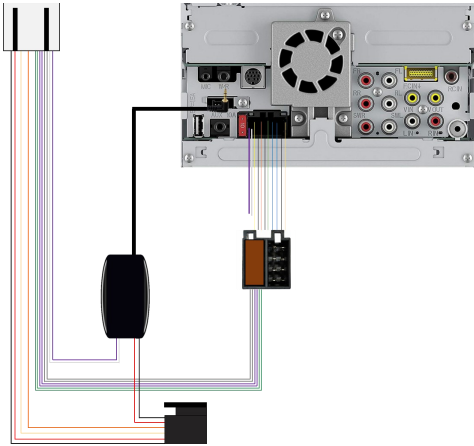

STEP 4

Connect the black ISO from the steering wheel interface (A) to the female ISO connector on the camera interface (B) **Then** Connect the Male ISO connector of the camera interface (C) to the wiring loom of the aftermarket head unit (D)

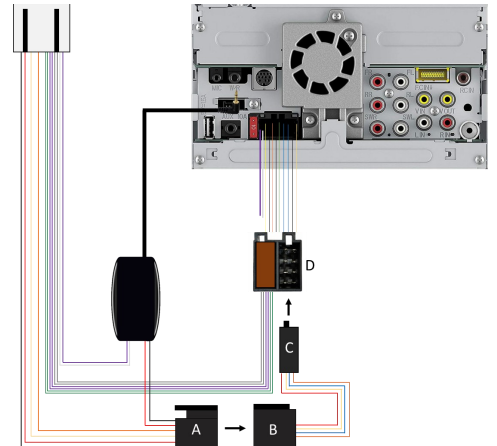

STEP 5

Connect the male RCA Plug of the camera interface to the camera input of the aftermarket head unit. This is usually a Brown Female RCA connection on the back of the unit but can vary depending on the manufacturer.

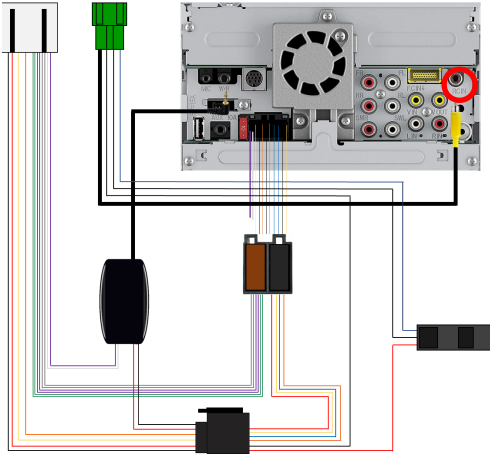

NOTE: Refer to the manufacturers instructions to confirm camera input connection.

STEP 6

Connect the loose reverse wire (Usually a Purple/White wire) leading out from the aftermarket radio wiring harness, to the dedicated reverse light supply. This is usually found at the rear/ reversing lights.



If there is no dedicated reverse feed from the original unit then you will need to use the dedicated 12v reverse light supply. This is found at the rear/ reversing lights

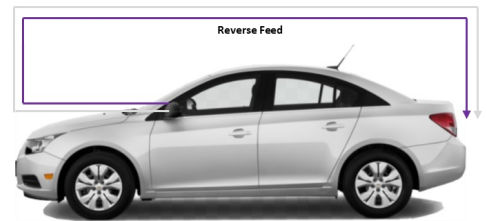

NOTE: These colours can vary depending on the make of head unit. Please refer to the manufacturers instructions.

STEP 7

Make the necessary connections to the wires leading out from the original radio. These are all shown in the diagram on the right.

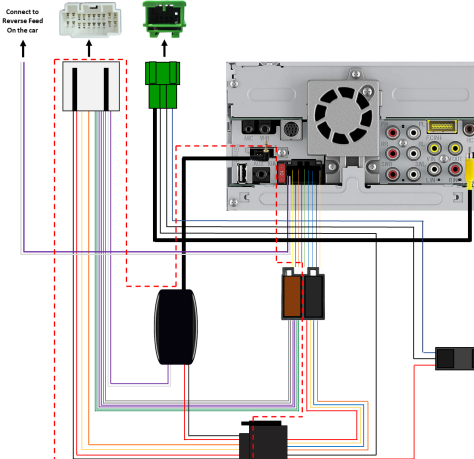

NOTE: The OEM connectors should look similar to the ones shown on the back of the OEM radio in step 1

STEP 8

Go into the menu settings on the aftermarket head unit to activate/ turn on camera.

NOTE: Picture is for demonstration purposes only and varies depending on the head unit you are installing. Refer to the manufacturers Instructions on how to do this.

