

# Facia Plate 2-DIN with pocket

Mercedes Actros

**GB**

## INSTALLATION INSTRUCTIONS

Expert Fitment Required

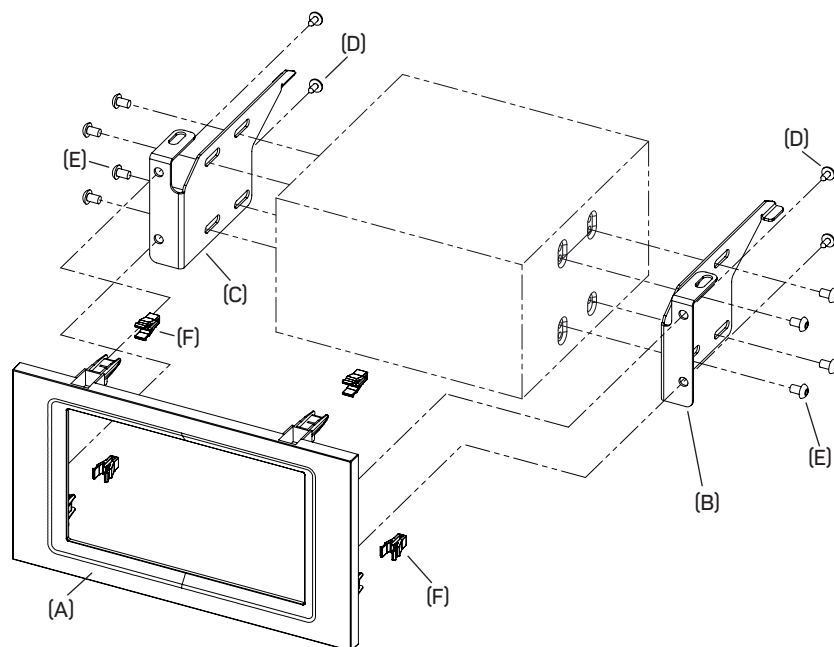

### 381190-46-1

(D) 4x	(E) 8x	(F) 4x

- (A) Facia Plate
- (B) Mounting Bracket Right
- (C) Mounting Bracket Left
- (D) Self-Tapping Screw with Collar
- (E) Flat Headed Screw
- (F) Clip

### 281190-46-1

(D) 4x	(E) 6x	(F) 4x
(G)		

- (G) Pocket (nur/only : 281190-46-1)





2x Torx TX25

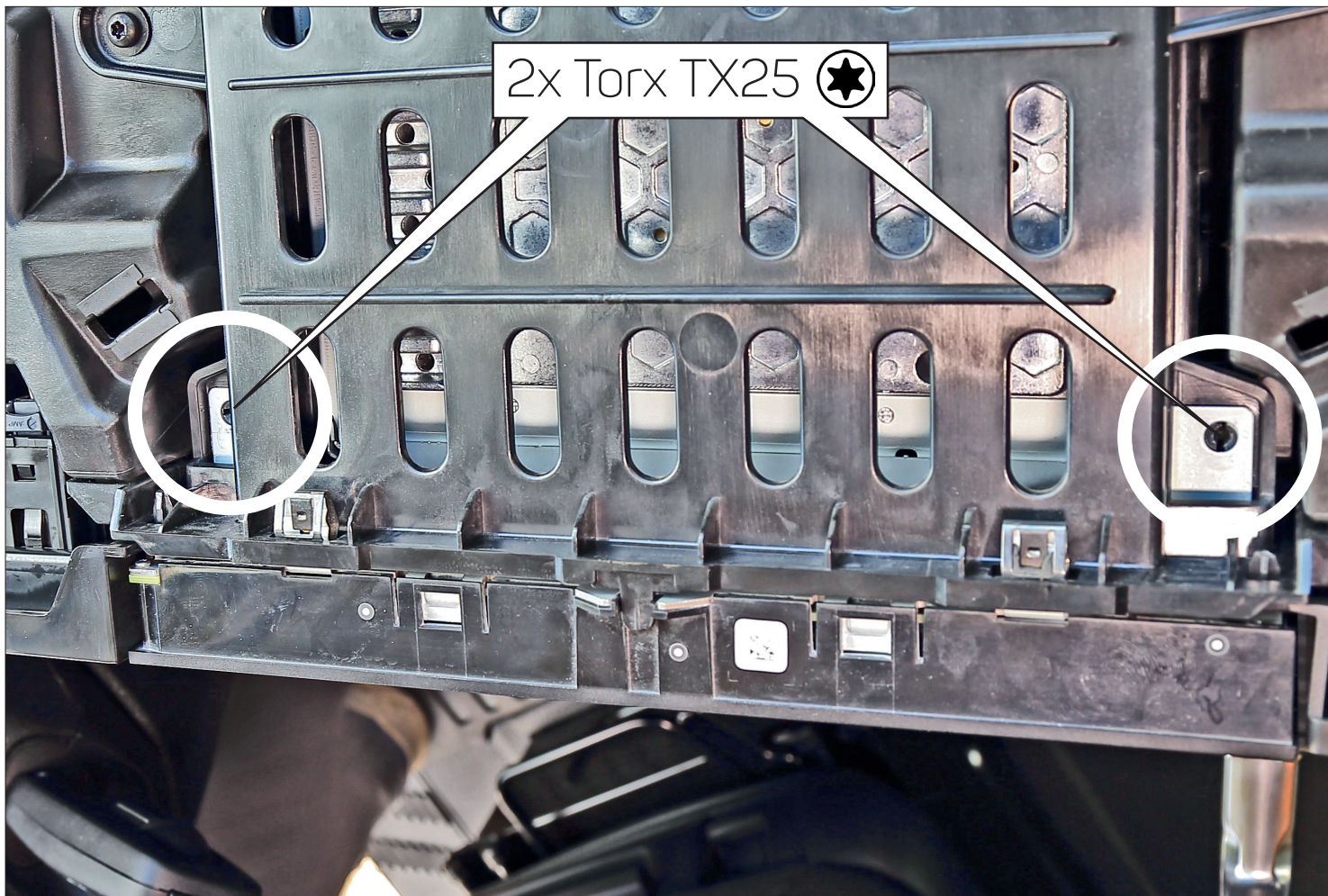

2x Torx TX25 ★

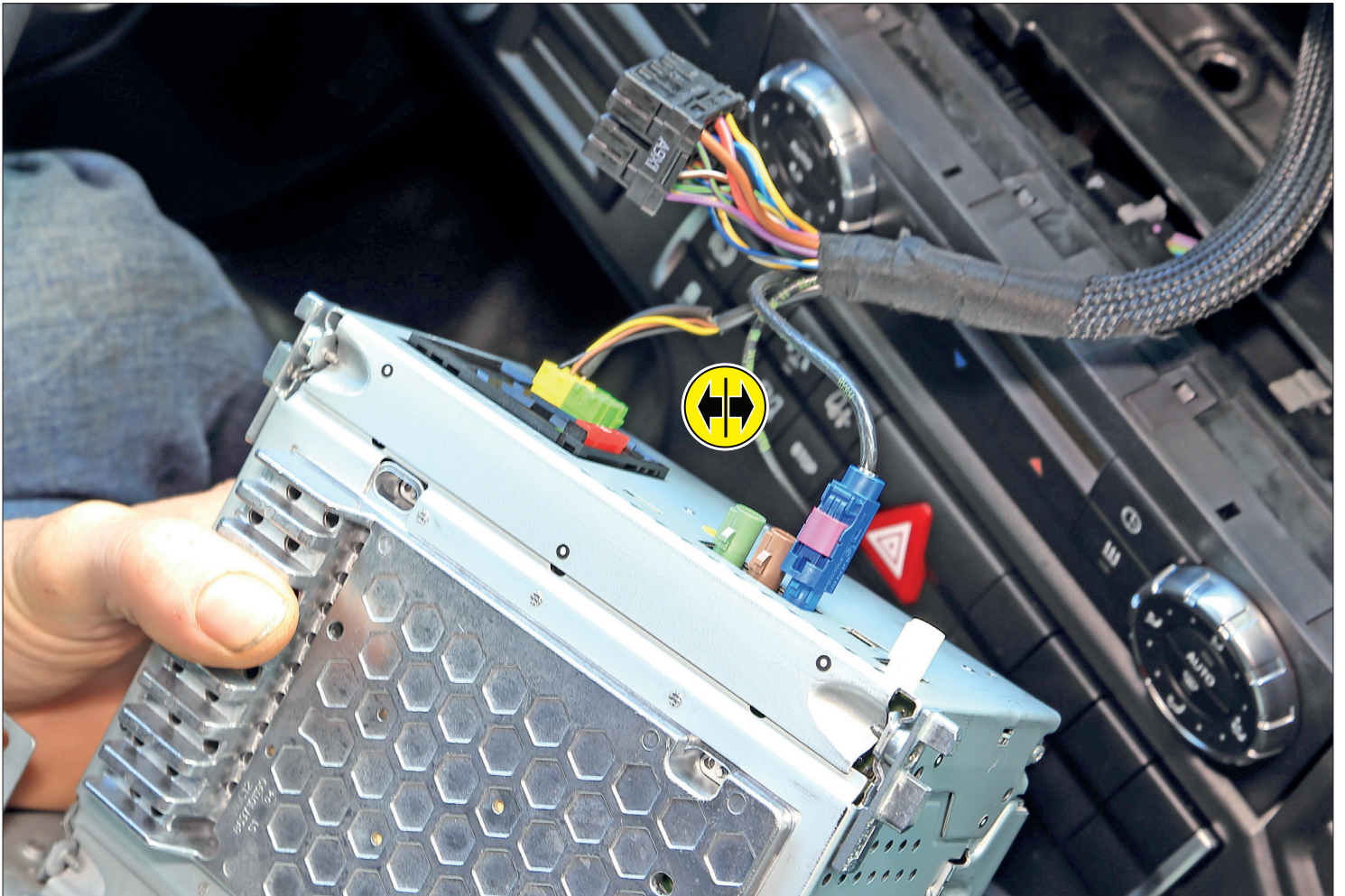

381190-46-1

2-DIN Radio

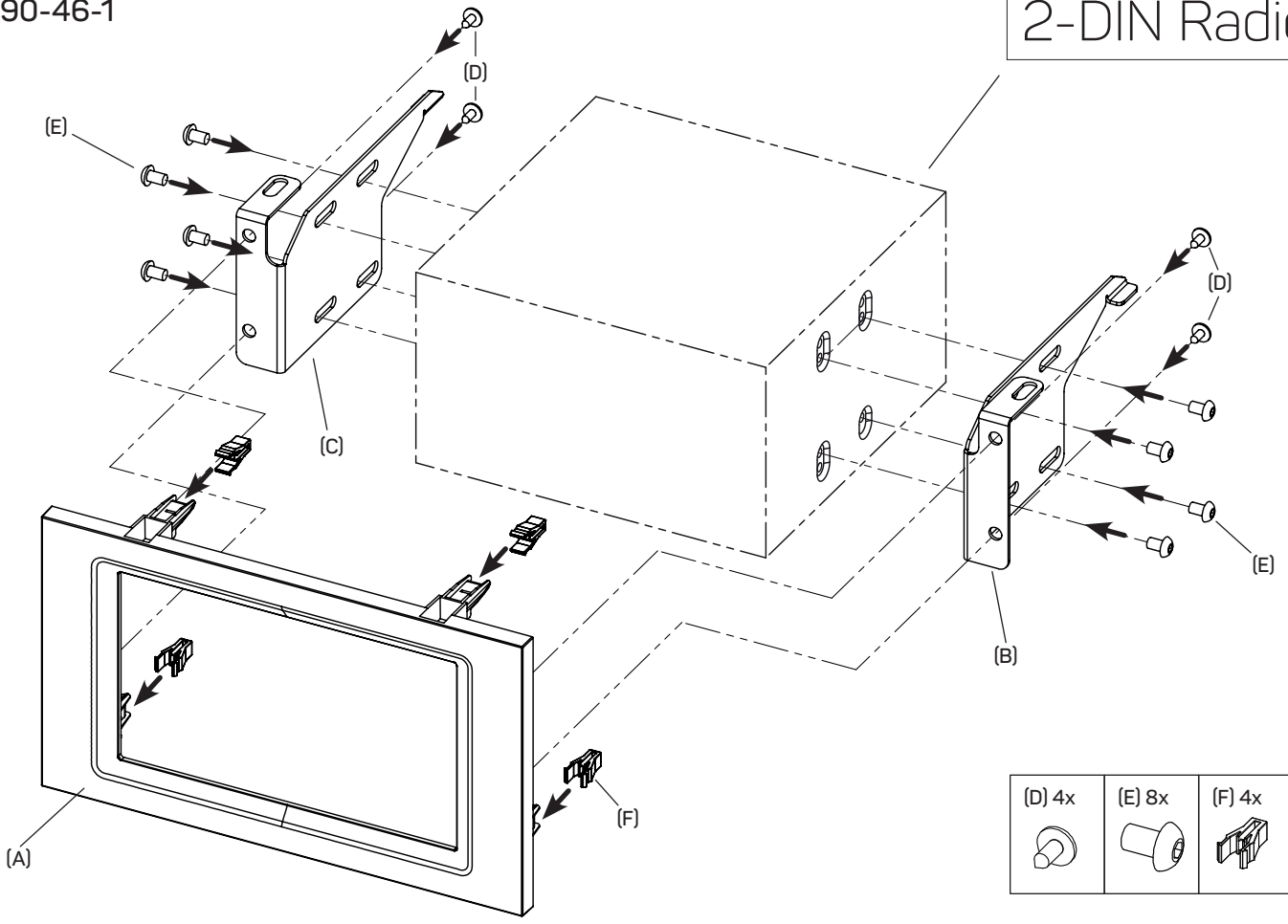

(D) 4x	(E) 8x	(F) 4x





