

Subaru Legacy, Subaru Outback 2015-up

KIT FEATURES

- Double DIN radio provision
- *Painted high gloss black*

KIT COMPONENTS

- A) Radio housing trim panel • B) Radio brackets

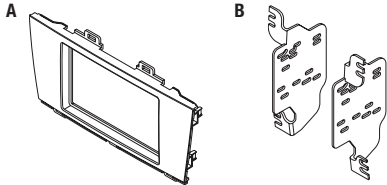

Table of Contents

Dash Disassembly

- Subaru Legacy 2015-up..... 2
- Subaru Outback 2015-up..... 2

Kit Assembly

- Double DIN radio provision 3

TOOLS REQUIRED

- Phillips screwdriver • Panel removal tool

CAUTION: We recommend disconnecting the negative battery terminal before beginning any installation. All accessories, switches, and especially air bag indicator lights must be plugged in before reconnecting the battery or cycling the ignition.

NOTE: Refer to the instructions included with the aftermarket radio.

Dash Disassembly

1. Unclip and remove the trim panel from around the climate controls. (Figure A)
2. Remove (2) Phillips screws securing the climate controls then unclip and remove them. (Figure B)
3. Unclip and remove the a/c vents above the factory radio. (Figure C)
4. Remove (4) Phillips screws securing the radio then unclip and remove the radio. (Figure D)
5. Unclip the four plastic panel clips from the factory radio and place them onto the radio trim panel.

Continue to kit assembly

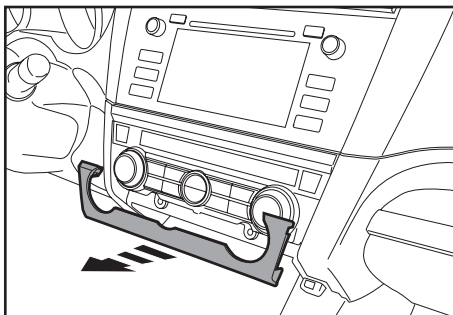

(Figure A)

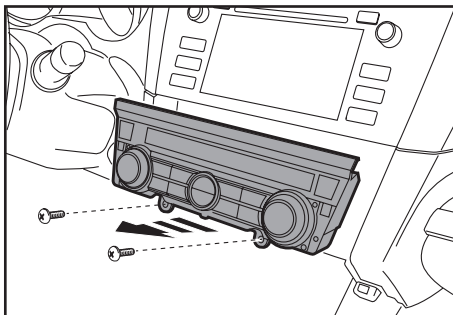

(Figure B)

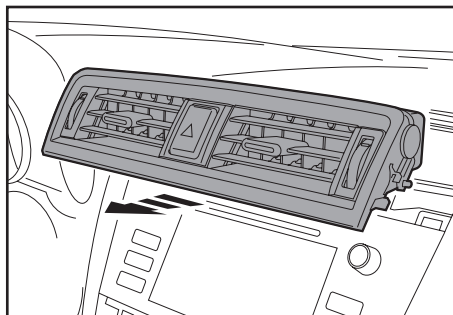

(Figure C)

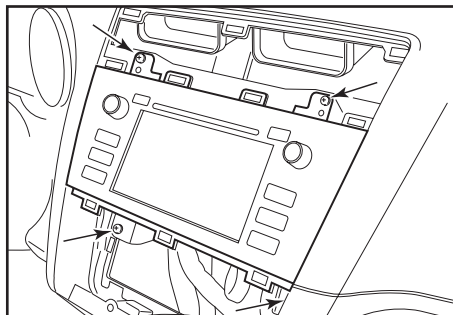

(Figure D)

Kit Assembly

Double DIN radio provision

1. Attach the brackets to the radio with the screws included with radio. (Figure A)
2. Locate the factory wiring harness and antenna plug in the dash and make all necessary wire connections to the radio.
3. Mount the new radio assembly into the dash.
4. Attach the (4) factory panel clips to the radio trim panel.
5. Reassemble the dash in the reverse order of disassembly using the radio trim panel.

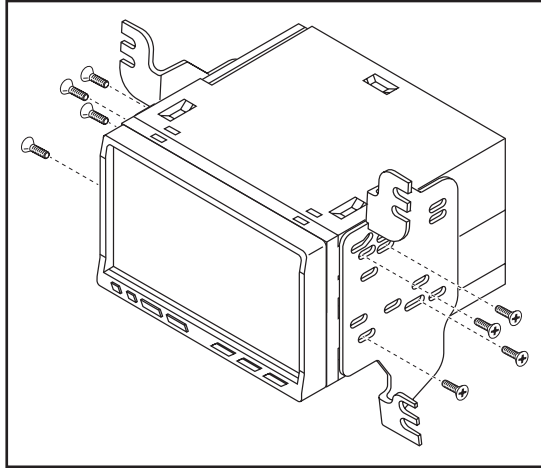

(Figure A)