



Kia Sportage LX (with base radio[†]) 2017-2019

[†] Base radio is a non-touchscreen radio

KIT FEATURES

- ISO DIN radio provision with pocket
- Painted scratch-resistant matte black

KIT COMPONENTS

- A) Radio trim panel • B) Radio brackets • C) Pocket • D) (2) #8 x 3/8" Phillips screws

A

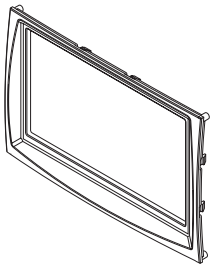

B

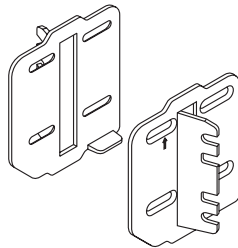

C

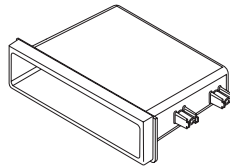

D



TABLE OF CONTENTS

Dash Disassembly	2
Kit Preparation	3
Kit Assembly	3

- Panel removal tool • Phillips screwdriver

CAUTION! All accessories, switches, climate controls panels, and especially air bag indicator lights must be connected before cycling the ignition. Also, do not remove the factory radio with the key in the on position, or while the vehicle is running.

DASH DISASSEMBLY

1. Unclip and slide the top of the center console back slightly. (Figure A)
2. Unclip and remove the panel on the end of the passenger side of the dash, then remove (1) Phillips screw exposed. (Figure B)
3. Unclip and remove the dash panel above the glove box. (Figure C)

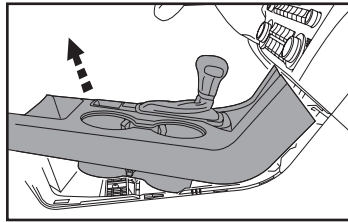

(Figure A)

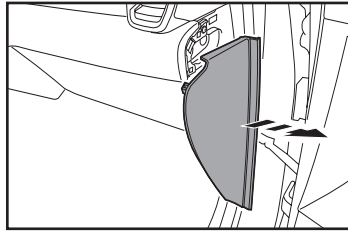

(Figure B)

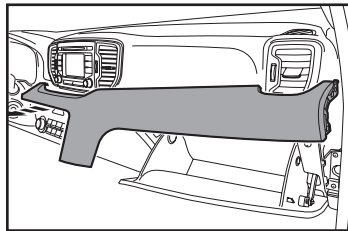

(Figure C)

4. Remove (2) Phillips screws securing the radio display and a/c vent panel, then unclip and remove the panel. (Figure D)
5. Remove (4) Phillips screws securing the radio. Slide the radio out, then unplug and remove the radio. (Figure E)

Continue to Kit Preparation

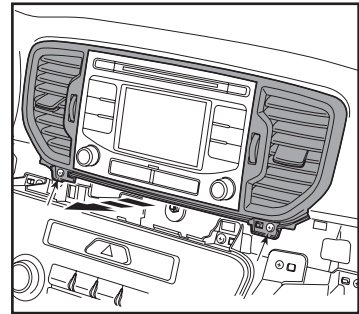

(Figure D)

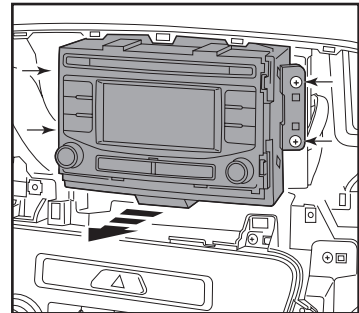

(Figure E)

KIT PREPARATION

Radio Trim Panel Installation

From the factory radio trim panel:

1. Remove (4) Phillips screws securing the inner trim panel, then remove the panel. (Figure A)

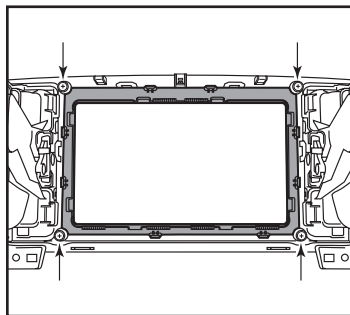

(Figure A)

To the factory radio trim panel:

2. Secure the *radio trim panel* to the panel using with the factory screws. (Figure B)

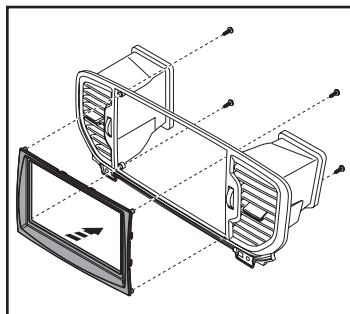

(Figure B)

Continue to Kit Assembly

KIT ASSEMBLY

1. Secure the *radio brackets* to the *pocket* using the (2) #8 x 3/8" Phillips screws provided. (Figure A)
2. Remove the metal DIN sleeve and trim ring from the aftermarket radio.
3. Slide the radio into the bracket/pocket assembly, then secure it to the assembly using the screws supplied with the radio. (Figure B)
4. Locate the factory wiring harness and antenna connector in the dash and complete all necessary connections to the radio.
5. Secure the radio assembly to the dash using the factory screws.
6. Reassemble the dash in reverse order of disassembly to complete the installation.

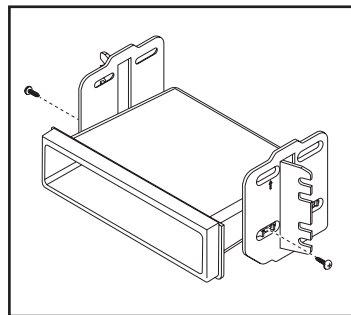

(Figure A)

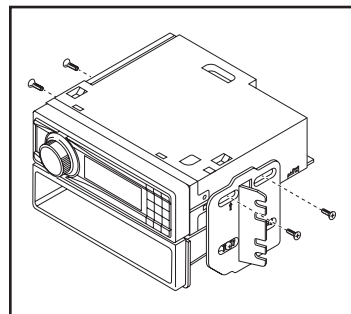

(Figure B)