

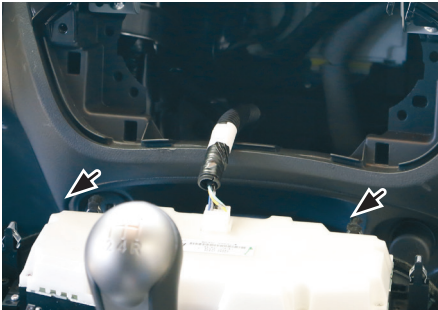

1. Unclip OEM panel

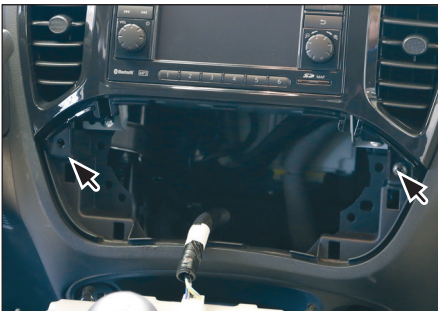

2. Remove OEM panel  
(see arrows)



3. Remove screws (see arrows)

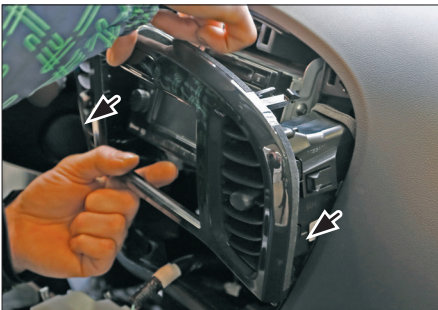

4. Remove upper panel by  
pulling it towards your  
direction (see arrows)



5. Remove screws of OEM  
head unit

Remove OEM head unit

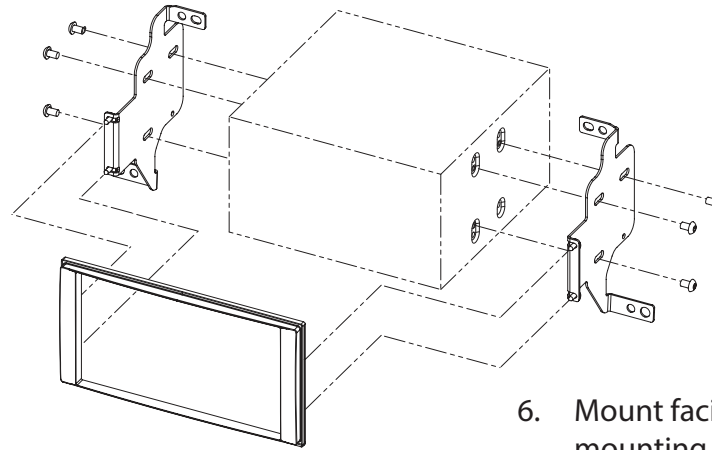

6. Mount fascia plate and  
mounting brackets to  
Double DIN head unit

7. Cut away plastic hooks (plain to surface) at the rear side of OEM panel

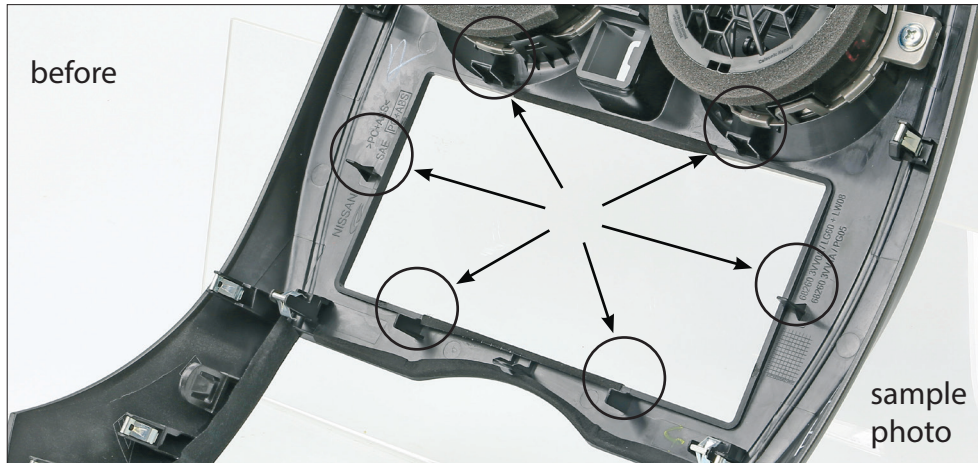

8. Connect all required circuit points. Mount double DIN head unit to dash board

re-install everything in reverse order to finish installation

*All installation work must be performed by a qualified professional installer only.  
The manufacturer / dealer is not liable for any kind of incidental or indirect damages.*