



### Kia Sorento

Without 7-inch touchscreen

#### KIT FEATURES

- ISO DDIN radio provision
- Painted scratch resistant black

#### KIT COMPONENTS

- A) Radio trim panel • B) Radio brackets

A

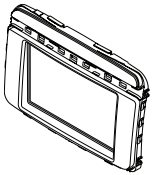

B

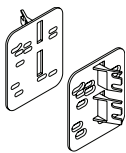

#### TABLE OF CONTENTS

Dash Disassembly .....	2
Kit Preparation .....	2
Kit Assembly .....	3

- Panel removal tool • Phillips screwdriver
- 10mm socket wrench • Cutting tool

## DASH DISASSEMBLY

1. Unclip and remove the factory radio trim panel including the a/c vents. (Figure A)
2. Remove (4) Phillips screws securing the radio. Slide the radio out, then unplug and remove the radio. (Figure B)

*Continue to Kit Preparation*

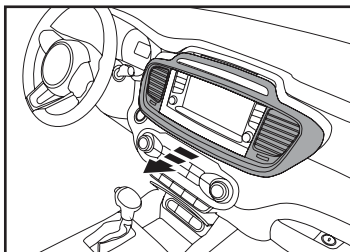

(Figure A)

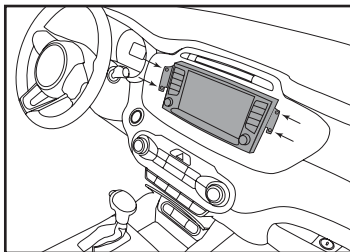

(Figure B)

## KIT PREPARATION

1. Cut the marked area in the dash cavity. (Figure A)
2. Remove (1) 10mm nut holding the area previously cut in step 1 to remove the cut-out area.
3. Snap the **radio trim panel** into the factory trim bezel from the back side of the bezel.

*Continue to Kit Assembly*

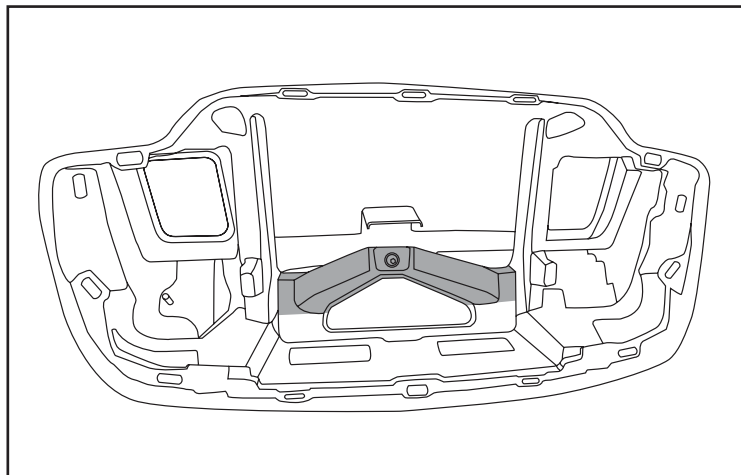

(Figure A)

## KIT ASSEMBLY

1. Secure the **radio brackets** to the radio using the screws supplied with the radio. (Figure A)
2. Locate the factory wiring harness and antenna connector in the dash and complete all necessary connections to the radio. Test the radio for proper operation.
3. Secure the radio assembly to the dash using the factory screws, then reassemble the dash in reverse order of disassembly to complete the installation.

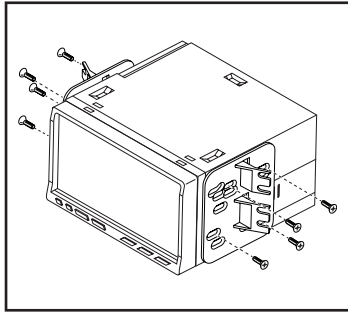

(Figure A)