

Fiat 500X 2016-up 50-952

KIT FEATURES

- ISO DDIN radio provision
- **Painted matte black**

KIT COMPONENTS

- A) Radio trim panel • B) Radio brackets

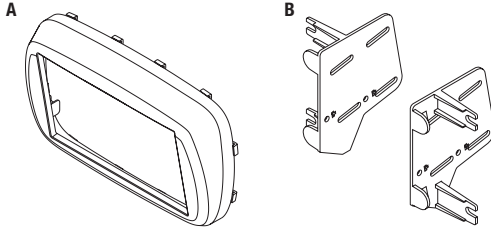

Table of Contents

Dash Disassembly	2
Kit Assembly	
– ISO DDIN radio provision	3

TOOLS REQUIRED

- Panel removal tool • Cutting tool
- T-25 Torx screwdriver

CAUTION! All accessories, switches, climate controls panels, and especially air bag indicator lights must be connected before cycling the ignition. Also, do not remove the factory radio with the key in the on position, or while the vehicle is running.

Dash Disassembly

1. Open upper storage compartment on passenger side. (Figure A)
2. Unclip, unplug, and remove painted hazard button panel below the radio. (Figure A)
3. Unscrew (2) T-25 Torx screws at the bottom of the radio trim. (Figure B)
4. Unclip the radio trim. (Figure B)
5. Unscrew (4) T-25 Torx screws securing the radio into the dash. (Figure C)
6. Unplug and remove the radio from the dash. (Figure C)
7. Cut the shaded areas in the dash cavity to gain suitable depth for the new radio chassis (**CAUTION: The vents are located directly behind the area to be cut, use extreme caution to not cut into them**). Be careful, you may want to make multiple cuts. (Figures D, E)

Continue to kit assembly.

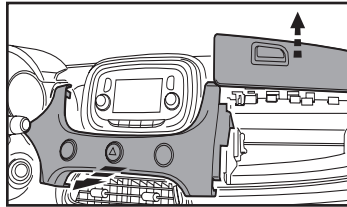

(Figure A)

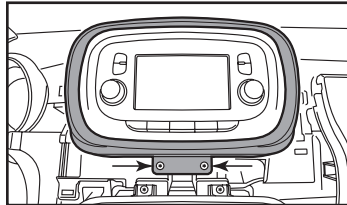

(Figure B)

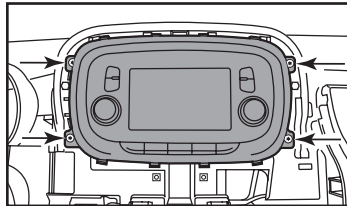

(Figure C)

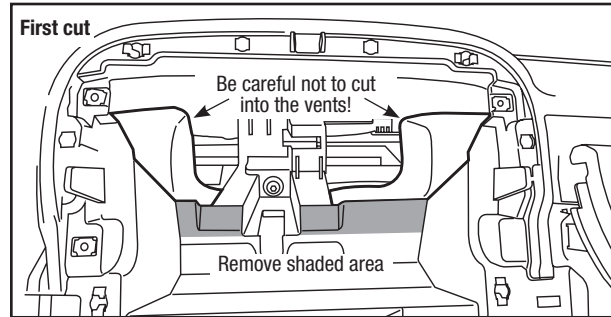

(Figure D)

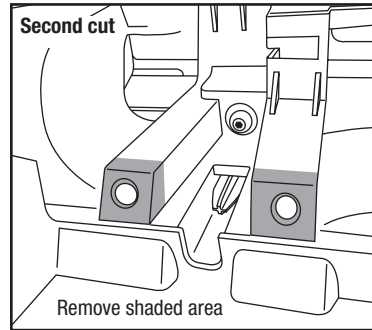

(Figure E)

Kit Assembly

ISO DDIN radio provision

1. Attach the *radio brackets* to the radio using the screws supplied with the radio. (Figure A)
2. Insert the *radio trim panel* into the factory radio trim removed in step 4 of dash disassembly. (Figure B)
3. Locate the factory wiring harness and antenna connector in the dash, complete all necessary connections to the radio and test the radio for proper operation.
4. Mount the radio into the dash using the factory hardware.
5. Reassemble the dash in the reverse order of disassembly.

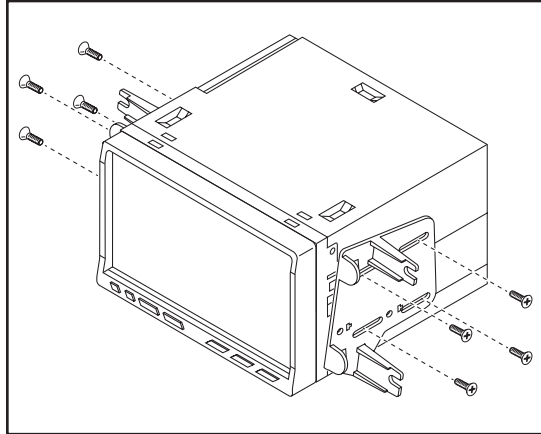

(Figure A)

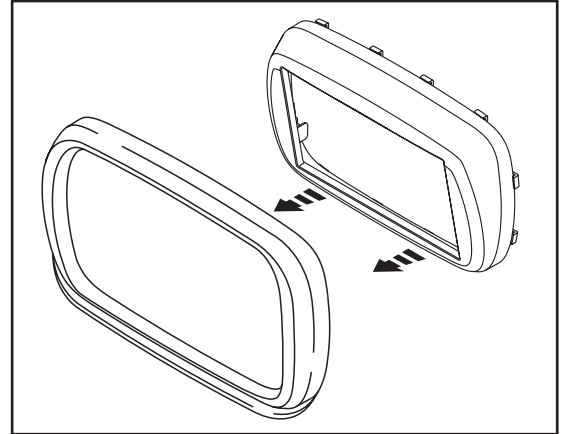

(Figure B)