



Chrysler 300 2005-2007

KIT FEATURES

- ISO DIN radio provision with pocket
- ISO DDIN radio provision
- Painted matte black

KIT COMPONENTS

- A) Radio housing trim panel
- B) Radio housing
- C) Radio brackets
- D) Pocket
- E) (7) Panel clips
- F) (8) #6 x 3/8" Phillips screws
- G) (4) #8 x 3/8" Phillips screws

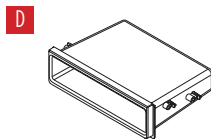
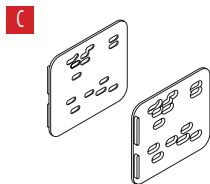
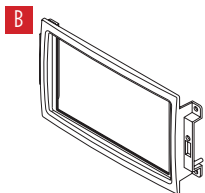
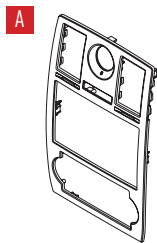

TABLE OF CONTENTS

Dash Disassembly	2
Kit Assembly	
–ISO DIN radio provision with pocket	3
–ISO DDIN radio provision.....	4

TOOLS REQUIRED

- Panel removal tool
- Phillips screwdriver
- 7mm Socket wrench

DASH DISASSEMBLY

1. Unclip and remove entire panel surrounding radio and climate controls, including A/C vents and clock. (Figure A)
2. Remove (4) 7mm screws securing radio to dash and remove radio. (Figure B)
3. Remove factory vents, clock, switch plate, and climate controls from the factory radio panel and transfer to the radio panel using the screws provided in this package.

Continue to Kit Assembly

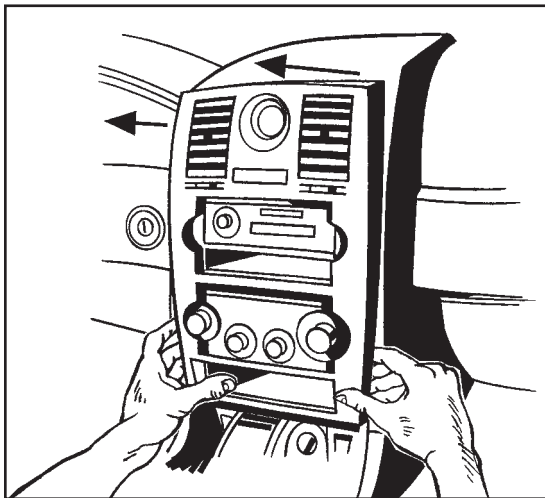

(Figure A)

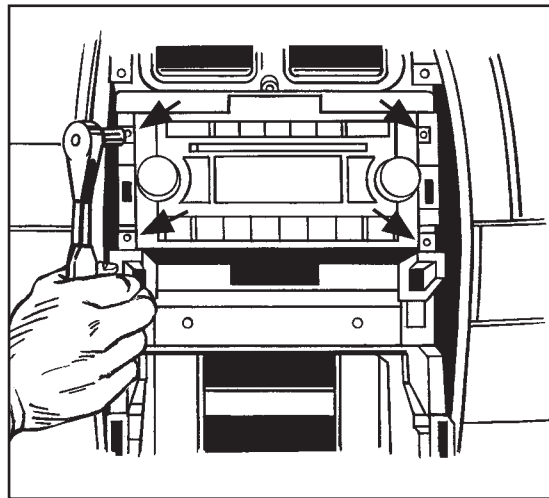

(Figure B)

KIT ASSEMBLY

ISO DIN radio provision with pocket

1. Attach the *radio brackets* to the *radio housing* by sliding the grooves in the brackets, into the housing. The following step will secure the brackets in place. (Figure A)
2. Attach the *pocket* to the *radio brackets* using the (4) #8 x 3/8" Phillips screws provided. (Figure B)
3. Remove the metal DIN sleeve and trim ring from the aftermarket radio.
4. Slide the radio into the bracket/pocket assembly, and then secure it using the screws supplied with the radio. (Figure C)

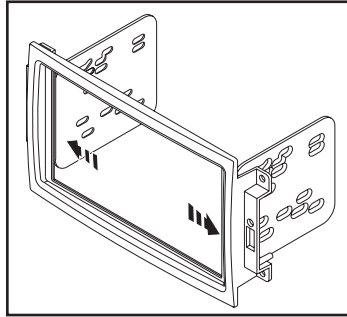

(Figure A)

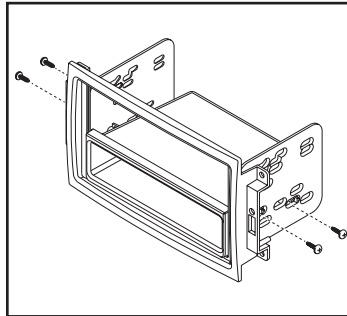

(Figure B)

5. Locate the factory wiring harness and antenna connector in the dash and complete all necessary connections to the radio. Test the radio for proper operation.
6. Secure the radio assembly to the dash using the factory screws.
7. Attach the (7) panel clips provided to the *radio housing trim panel*, then reassemble the dash in reverse order of disassembly using the *radio housing trim panel* to complete the installation.

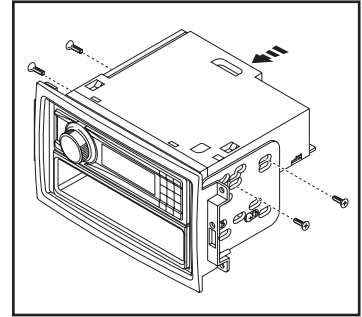

(Figure C)

KIT ASSEMBLY

ISO DDIN radio provision

1. Attach the *radio brackets* to the *radio housing* by sliding the grooves in the brackets, into the housing. The following step will secure the brackets in place. (Figure A)
2. Attach the *radio brackets* to the radio using the screws supplied with the radio. (Figure B)
3. Locate the factory wiring harness and antenna connector in the dash and complete all necessary connections to the radio. Test the radio for proper operation.
4. Secure the radio assembly to the dash using the factory screws.
5. Attach the (7) panel clips provided to the *radio housing trim panel*, then reassemble the dash in reverse order of disassembly using the **99-6516B** *radio housing trim panel* to complete the installation.

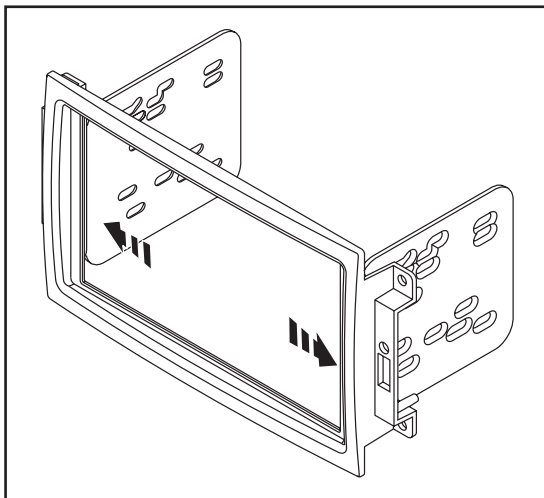

(Figure A)

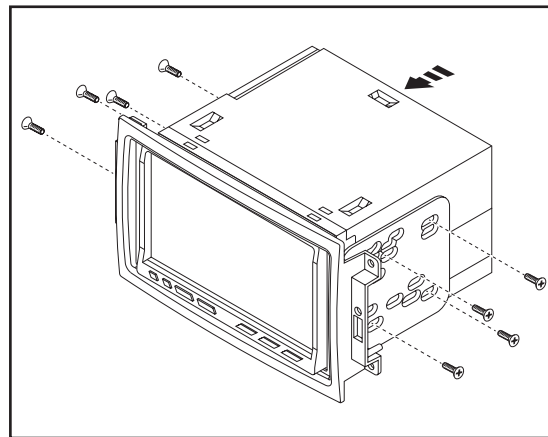

(Figure B)