



Kia Sorento 2011-2013

KIT FEATURES

- ISO DDIN radio provision
- Painted matte black to match the factory finish

KIT COMPONENTS

- A) Radio housing • B) Radio brackets

A

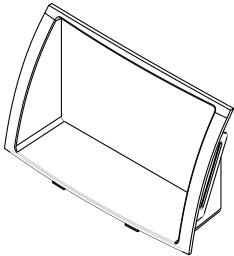

B

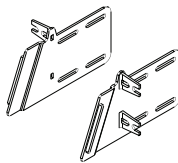

TABLE OF CONTENTS

Dash Disassembly	2
Kit Assembly	3

- Phillips screwdriver

CAUTION! All accessories, switches, climate controls panels, and especially air bag indicator lights must be connected before cycling the ignition. Also, do not remove the factory radio with the key in the on position, or while the vehicle is running.

DASH DISASSEMBLY

1. Remove shifter knob. (Figure A)
2. Remove the shifter surround panel. (Figure B)
3. Remove panel under the heater and air climate controls. (Figure C)
4. Remove (2) Phillips screws from bottom and remove center fascia panel. (Figure D)
5. Remove (4) Phillips screws securing the heater and air climate controls. (Figure E)
6. Remove (4) Phillips screws securing the radio. Slide the radio out, then unplug and remove the radio. (Figure F)

Continue to Kit Assembly

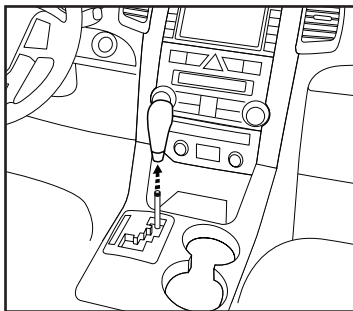

(Figure A)

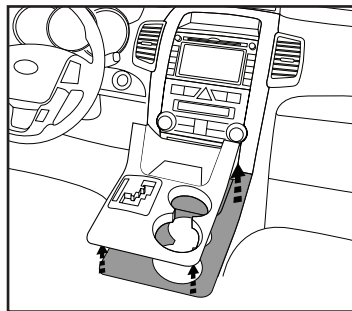

(Figure B)

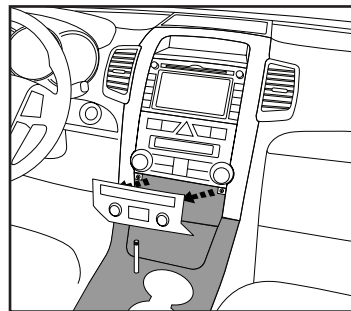

(Figure C)

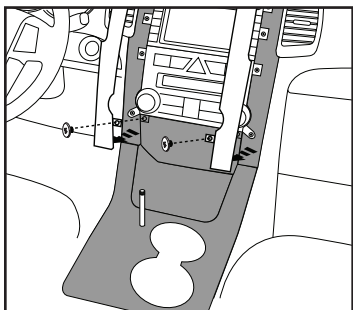

(Figure D)

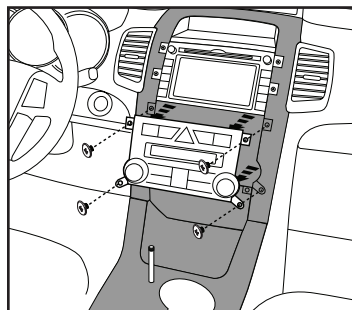

(Figure E)

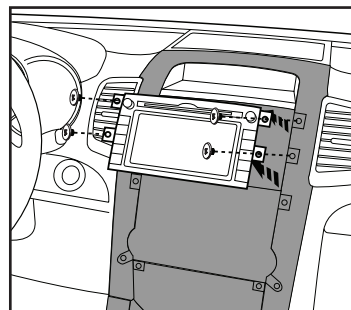

(Figure F)

KIT ASSEMBLY

1. Attach the *radio brackets* to the *radio housing*. (Figure A)
2. Slide the radio into the bracket/radio housing assembly from the rear, then secure the radio to the assembly using the screws supplied with the radio. (Figure B)
3. Locate the factory wiring harness and antenna connector in the dash.
4. Secure the radio assembly to the dash using the factory screws, then reassemble the dash in reverse order of disassembly to complete the installation

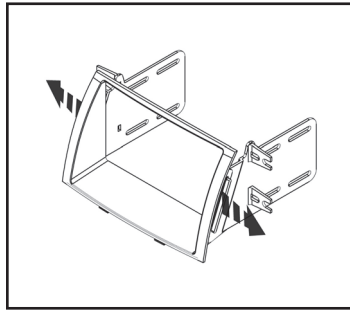

(Figure A)

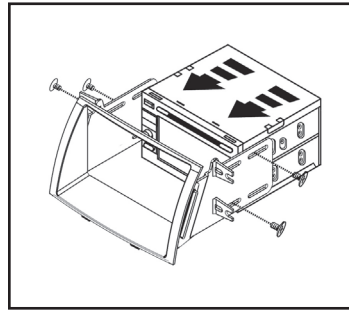

(Figure B)