

APPLICATIONS

Hyundai Accent 2006-2011

Kia Rio/RIO 5 2006-up

Kia Sportage 2005-2010

50-759

KIT FEATURES

- DDIN head unit provision
 - ISO stacked head unit provision
-

KIT COMPONENTS

- A) DDIN radio housing
 - B) DDIN radio housing brackets
-

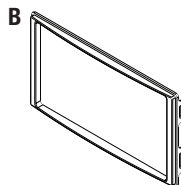
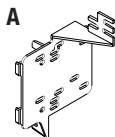

TOOLS REQUIRED

Panel Removal Tool • Phillips Screwdriver • Small Flat Blade Screwdriver • Cutting Tool

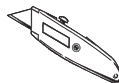
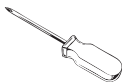
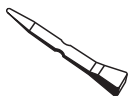

Table of Contents

Dash Disassembly

- Hyundai Accent 2006-2011
- Kia Rio/RIO 5 2006-up3
- Kia Sportage 2005-20104

Kit Preparation5

Kit Assembly

- DDIN/stacked ISO DIN head unit provision6

Hyundai Accent 2006-2011 Kia Rio/RIO 5 2006-up

1. Unclip and remove the trim panel surrounding the radio and including the a/c vents. (Figure A)
2. Remove (4) Phillips screws securing the radio. (Figure B)

Continue to kit preparation

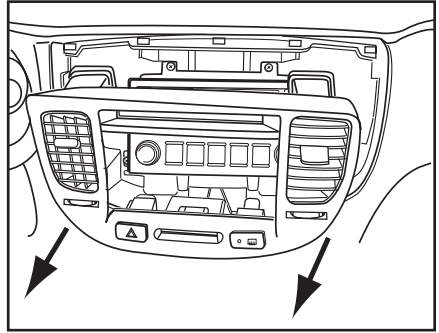

(Figure A)

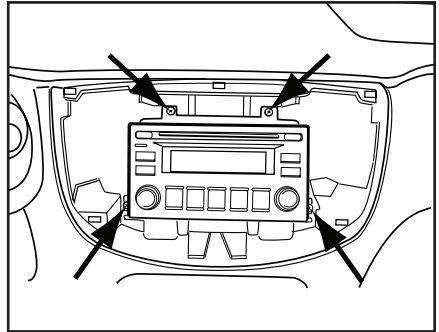

(Figure B)

Kia Sportage 2005-2010

1. Unclip and remove the entire panel surrounding the radio and including the A/C controls. **Note: Start at bottom of panel.** (Figure A)
2. Remove (4) Phillips screws to extract radio from dash. (Figure B)

Continue to kit preparation

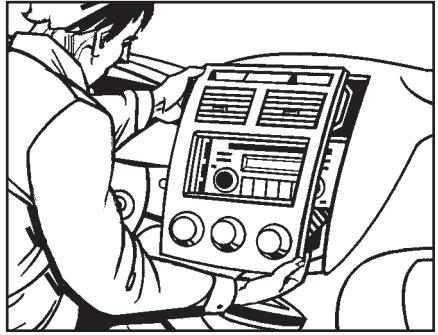

(Figure A)

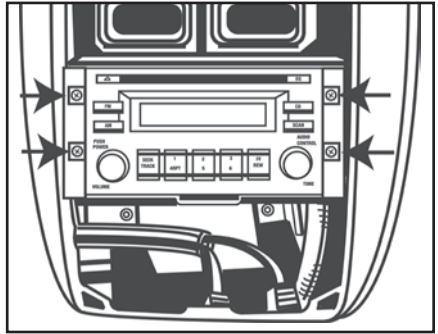

(Figure B)

Kit Preparation

1. Hyundai Accent: Cut and remove shaded areas. (Figure A)
2. Kia Rio: Cut and remove shaded areas. (Figure B)
3. Kia Sportage: Cut and remove shaded areas. (Figure C)

Continue to kit assembly

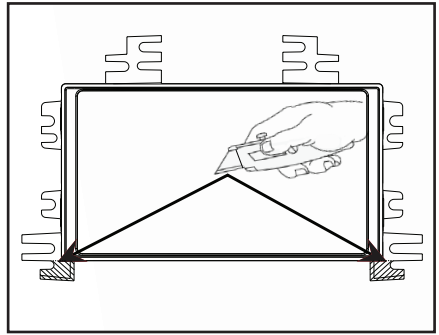

(Figure A)

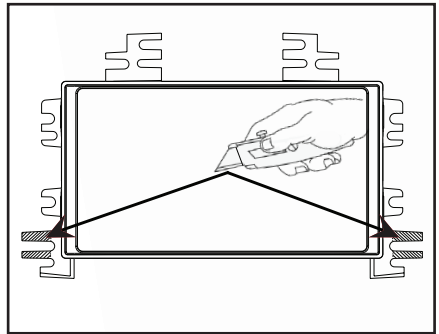

(Figure B)

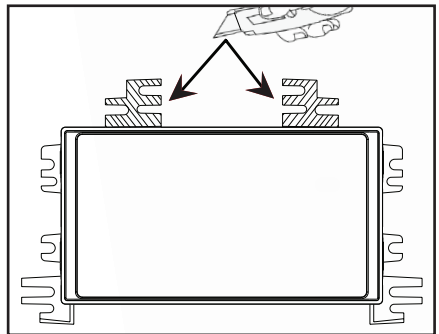

(Figure C)

Double DIN/stacked ISO DIN head unit provision

1. Locate the factory wiring harness in the dash. Metra recommends using the proper mating adapter from Metra or AXCESS. Re-connect the negative battery terminal and test the unit for proper operation.
2. Attach the Double DIN brackets to the inside edge of the Double DIN trim plate. (Figure A)
3. Slide the Double DIN head unit or stacked ISO head units into the bracket/ radio housing assembly and secure the Double DIN head unit or stacked ISO head units to the assembly using the screws supplied with the radio. (Figure B)
4. Reassemble dash in reverse order of disassembly.

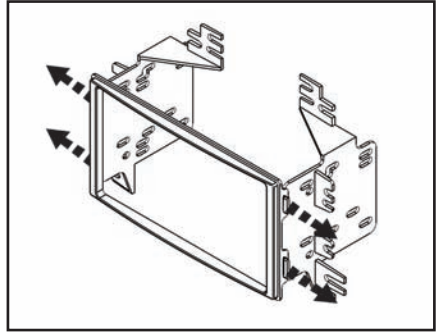

(Figure A)

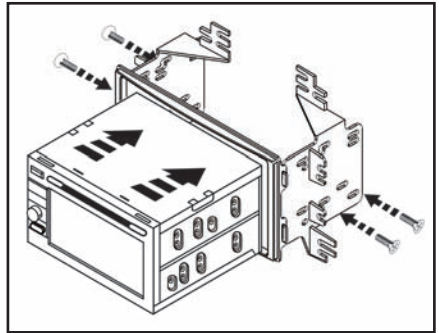

(Figure B)