

APPLICATIONS

Lexus RX330 2004-2006/RX350 2007-2009/ RX400H 2006-2009 50-796

KIT FEATURES

- ISO DIN radio provision with pocket
- Double DIN radio provisions
- *Painted silver to match factory finish*



KIT COMPONENTS

- A) Radio trim panel • B) Radio brackets • C) Pocket • D) (4) #8 x 3/8" Phillips screws • E) Resistor

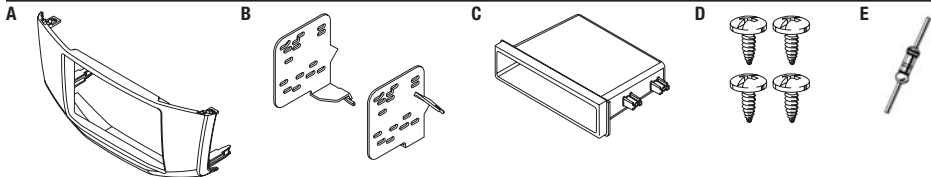

TOOLS REQUIRED

- Panel removal tool • Phillips screwdriver • Socket wrench

Table of Contents

Dash Disassembly

- Lexus RX350 2007-2009 2
- Lexus RX400H 2006-2009 2
- Lexus RX330 2004-2006 2

Kit Assembly

- ISO DIN radio provision with pocket..... 2
- Double DIN radio provisions 3

- Wiring Diagram..... 3

Dash Disassembly

1. Unsnap and remove shifter trim. (Figure A)
2. Unsnap and remove power outlet panel below radio. (Figure B)
3. Remove four 10 mm bolts securing radio, unsnap, and remove. (Figure C)
4. Remove two plastic snaps from factory radio and install onto radio panel.

Continue to kit assembly

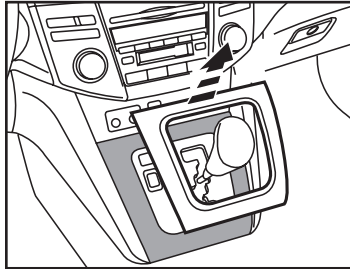

(Figure A)

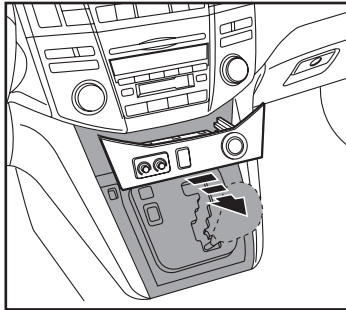

(Figure B)

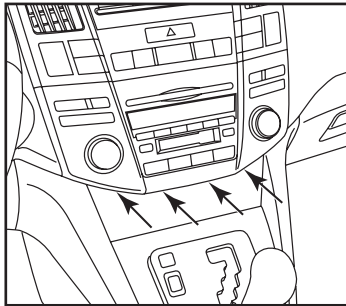

(Figure C)

Kit Assembly

ISO DIN radio provision with pocket

1. Mount the pocket to the radio brackets with the (4) #8 x 3/8" Phillips screws supplied. (Figure A)
2. Slide the radio into radio brackets and secure with screws supplied with the radio. (Figure A)
3. Locate the factory wiring harness and antenna plug in the dash.
4. Mount the new radio assembly into the dash snap the radio panel over that and reassemble dash in reverse order of disassembly.

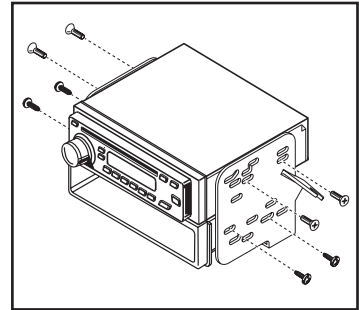

(Figure A)

Kit Assembly

Double DIN radio provision

1. Mount the radio brackets to the aftermarket radio and secure with screws supplied with the radio. (Figure A)
2. Locate the factory wiring harness and antenna plug in the dash.
3. Mount the new radio assembly into the dash and reassemble dash in reverse order of disassembly.

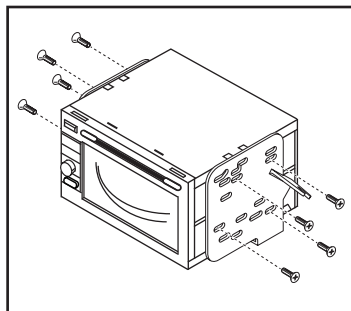

(Figure A)

Wiring Diagram

For the climate controls to operate properly, the following steps need to be followed:

1. Locate the 20-way or 12-way white connector that was plugged into the factory radio.

Note: 04'-06' RX330 & 06' RX400H have a 12-way connector and require the resistor to be added between the Yellow in pin 9 and Brown in pin 10.

Note: 07'-09' RX350 & 07'-09' RX400H have a 20-way connector and require the resistor to be added between the Red in pin 9 and Black in pin 10.

Note: 07'-09' RX350 & 07'-08' RX400H with factory navigation have a 12-way connector and require the resistor to be added between the Black in pin 9 and White in pin 10.

2. Strip back the two factory wires, connect one side of the 68 OHM resistor to one wire and connect the other side of the resistor to the other wire (see diagram below).
3. When completed be sure to tape up the wires including the resistor to protect them from coming into contact with any metal, and push the connector back into the dash (see diagram below).

