

## **APPLICATIONS** **SMART FORTWO**

# 50-740

### **KIT FEATURES**

- DIN Radio Provision With Pocket
- ISO Mount Radio Provision With Pocket
- Double DIN Radio Provision
- Stacked ISO Mount Units Provision



### **KIT COMPONENTS**

- A) Radio Housing • B) Trim Plate • C) ISO Brackets • D) Double DIN Trim Plate
- E) Double DIN Brackets • F) Pocket

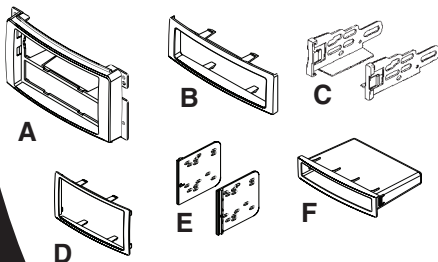

### **TOOLS REQUIRED:**

- Phillips Screwdriver/ Panel Removal Tool
- T-20 Torx Screwdriver



# **TABLE OF CONTENTS**

## **Dash Disassembly**

**- Smart Fortwo .....1**

## **Kit Assembly**

**- DIN Radio Provision with Pocket .....2**

**- ISO Mount Radio Provision with Pocket .....3**

**- Double DIN/Stacked ISO Mount Units Provision.....4**

**Final Assembly .....5**

### **\*Note:**

**Refer also to the instructions included with the aftermarket radio.**

## SMART FORTWO

- 1 Disconnect the negative battery terminal to prevent an accidental short circuit.
- 2 Unclip the Hazard button switch panel. (Figure A)
- 3 Remove (1) T-20 Torx head screw. (Figure B)
- 4 Carefully unclip the panel surrounding the radio, start at the top of the dash and work your way down. (Figure C)
- 5 Remove (4) T-20 Torx head screws from around the radio. (Figure D)
- 6 Remove radio and disconnect the wire harness and antenna.

*Continue to kit assembly.*

A

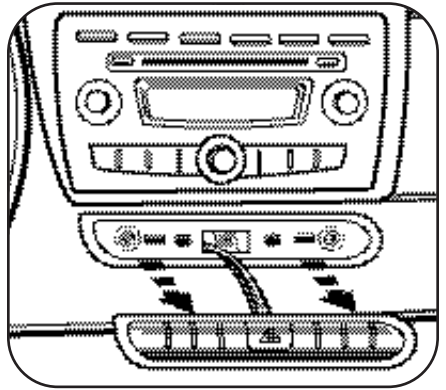

B

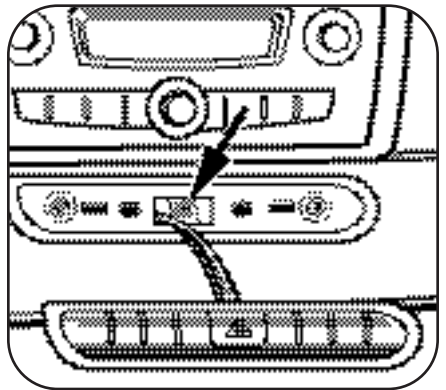

D

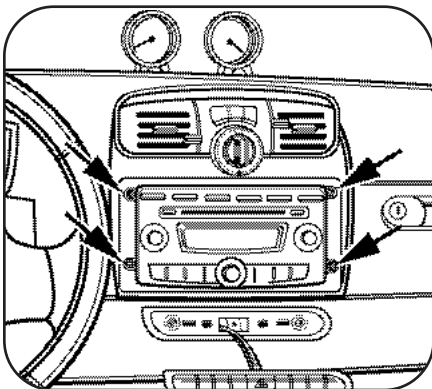

C

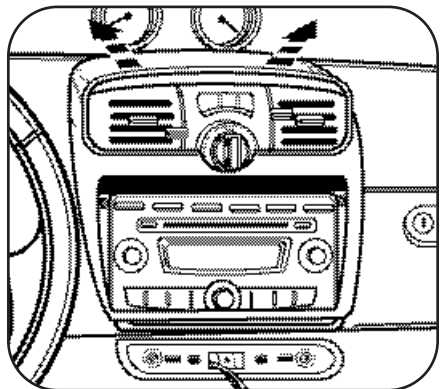

## **DIN RADIO PROVISION WITH POCKET**

***Note: Refer also to the instructions included with the aftermarket radio.***

- 1** Slide the DIN cage into the radio housing and secure by bending the metal locking tabs outward. (Figure A)
- 2** Slide the aftermarket radio into the cage until it snaps into place. (Figure B)
- 3** Snap the pocket into the radio housing. (Figure C)

*Continue to final assembly.*

**A**

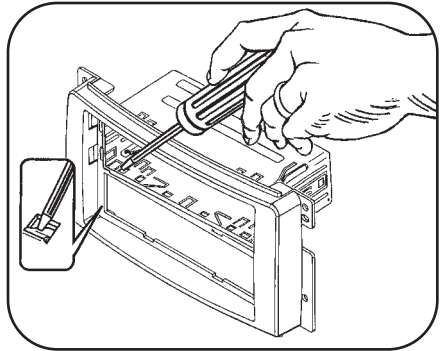

**B**

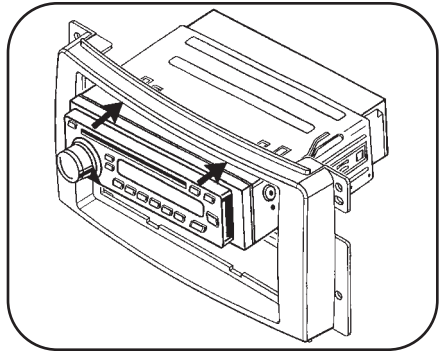

**C**

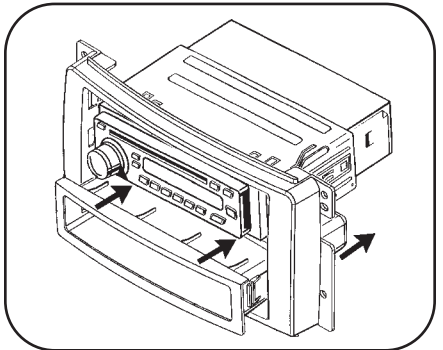

# **ISO MOUNT RADIO PROVISION WITH POCKET**

*Note: Refer also to the instructions included with the aftermarket radio.*

- 1** Mount the ISO Brackets to the aftermarket radio using the screws supplied with the radio. (Figure A)
- 2** Slide the radio/bracket assembly into the radio housing until it snaps into place. (Figure B)
- 3** Snap the pocket into the radio housing. (Figure C)
- 4** Snap the Trim plate onto the front of the radio housing. (Figure D)

*Continue to final assembly.*

**A**

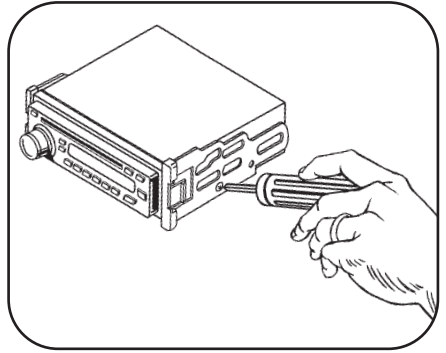

**B**

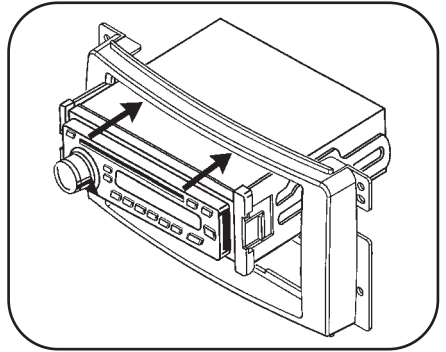

**C**

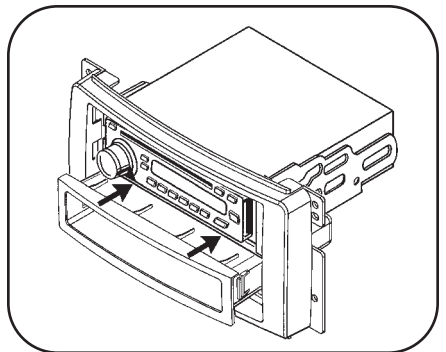

**D**

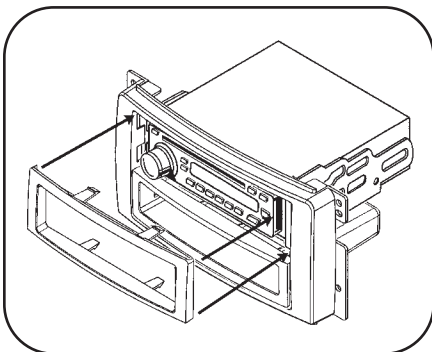

## **DOUBLE DIN/STACKED ISO MOUNT UNITS PROVISION**

*Note: Refer also to the instructions included with the aftermarket radio.*

- 1** Cut and remove the center bar from the radio housing. (Figure A)
- 2** Snap the Double DIN brackets to the inside edge of the radio housing. (Figure B)
- 3** Slide the Double DIN or stacked ISO mount unit(s) into the bracket/radio housing assembly and secure the unit(s) to the assembly using the screws supplied with the unit(s). (Figure C)
- 4** Snap the Double DIN trim plate onto the front of the radio housing. (Figure C)

*Continue to final assembly.*

**A**

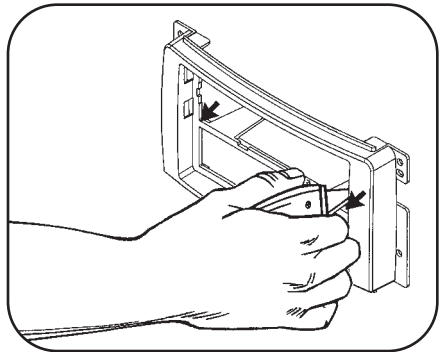

**B**

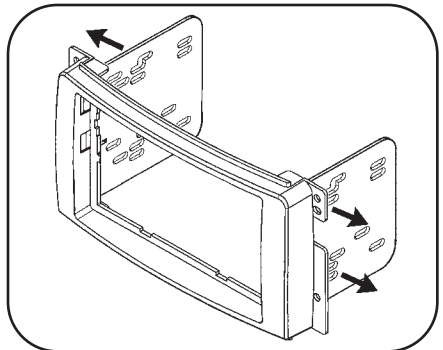

**C**

