

APPLICATIONS

2005-2007 Suzuki Aerio

50-296

KIT FEATURES

- DIN head unit provision
- ISO DIN head unit provision



KIT COMPONENTS

A) Radio Housing | B) ISO Brackets | C) Trim Plate

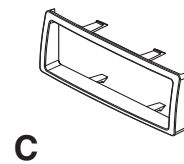
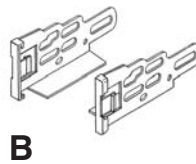
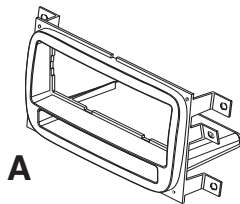

TOOLS REQUIRED:

Phillips Screwdriver | Small Flat Blade Screwdriver | Utility Knife

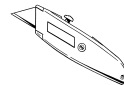
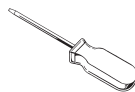
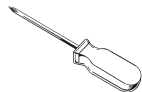

2005-2007 SUZUKI AERIO

- 1** Disconnect the negative battery terminal to prevent an accidental short circuit.
- 2** Unclip and remove the trim panels from both sides of radio/climate controls. (Figure A)
- 3** Remove (4) Phillips screws holding radio to sub dash and remove radio. (Figure B)
- 4** Remove (4))Phillips screws securing the radio and brackets to the factory radio trim panel. (Figure C)

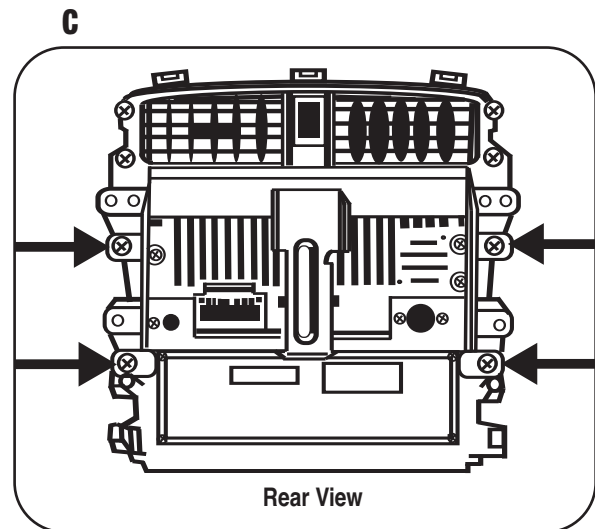
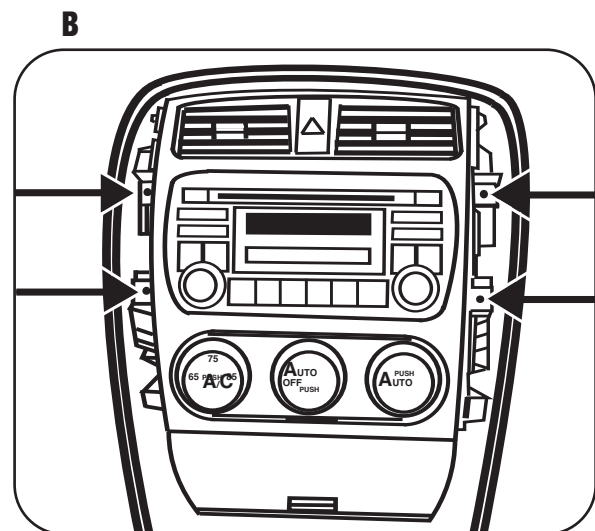
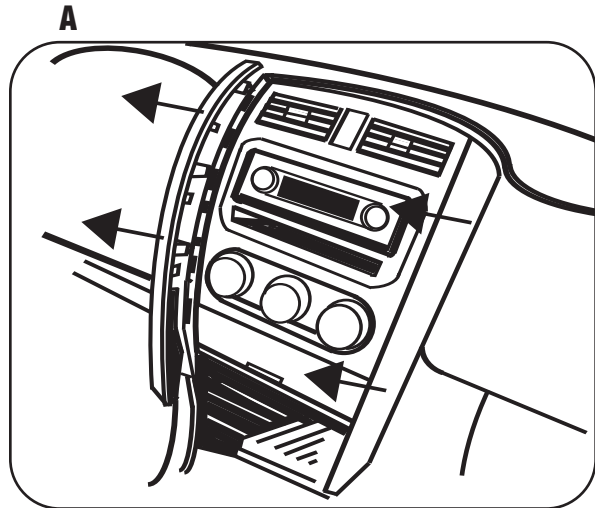

DIN HEAD UNIT PROVISION

- 1** Cut and remove the center bar in the DIN opening of the 50-296 Radio Housing.
- 2** Secure the 50-296 radio housing to the factory radio trim panel using the factory hardware.
- 3** Slide the DIN cage into the Radio Housing and secure by bending the metal locking tabs down. **(Figure A)**
- 4** Slide the aftermarket head unit into the cage and secure. **(Figure B)**

A

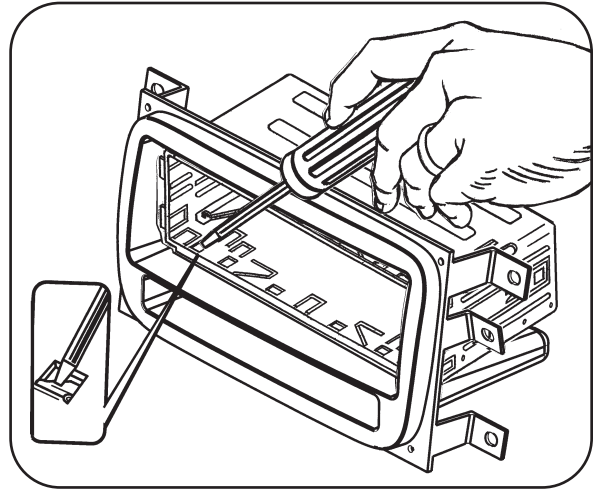

B

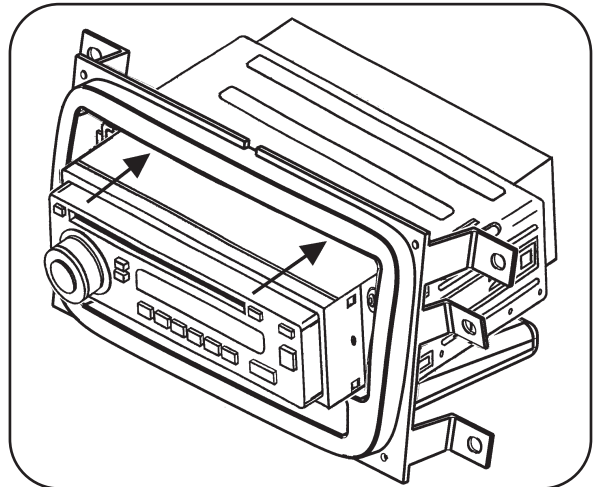

ISO DIN HEAD UNIT PROVISION

- 1 Cut and remove the center bar in the DIN opening of the 50-296 Radio Housing.
- 2 Secure the 50-296 radio housing to the factory radio trim panel using the factory hardware.
- 3 Mount the ISO Brackets to the head unit with the screws supplied with the unit. **(Figure A)**
- 4 Slide the head unit into the radio opening until the side clips engage. **(Figure B)**
- 5 Snap the Trim plate into the Radio Housing. **(Figure B)**

A

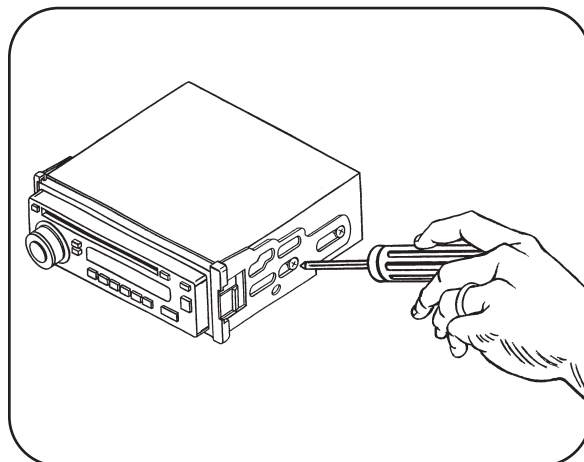

B

