

50-695

Hyundai Entourage 2007-2008 Kia Sedona 2006-2014

KIT FEATURES

- Double DIN radio provision



KIT COMPONENTS

- A) Double Trim plate • B) Double DIN brackets

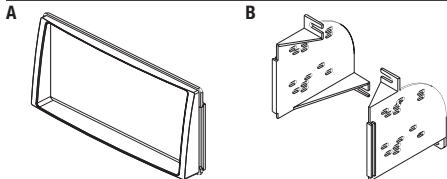

Table of Contents

Dash Disassembly

- Hyundai Entourage 2007-2008
- Kia Sedona 2006-2014 2

Kit Assembly

- Double DIN radio provision..... 3

TOOLS REQUIRED

- Phillips screwdriver • Panel removal tool

CAUTION: All accessories, switches, and especially air bag indicator lights must be plugged in before reconnecting the battery or cycling the ignition.

NOTE: Refer to the instructions included with the aftermarket radio.

Dash Disassembly

1. Unclip and remove panel surrounding shifter. (Figure A)
2. Remove (2) Phillips screws at bottom corners of panel surrounding radio. (Figure B)
3. Unclip and remove entire panel surrounding radio including the clock and a/c vents. (Figure C)
4. Remove (4) Phillips screws securing radio.
5. Unplug and remove the radio.

Continue to kit assembly

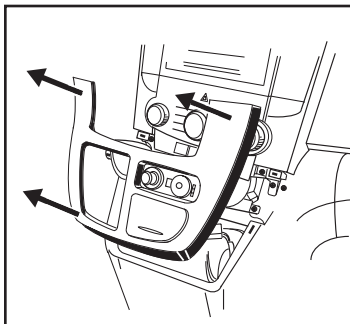

(Figure A)

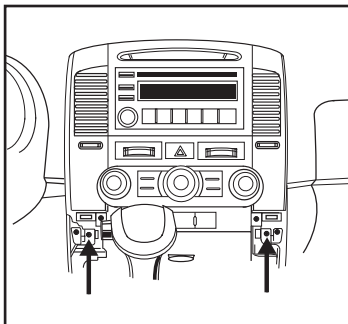

(Figure B)

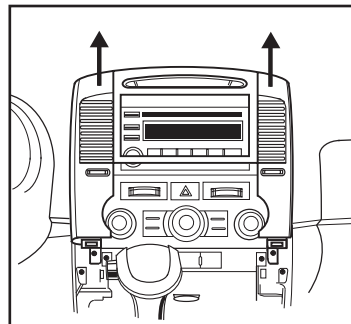

(Figure C)

Kit Assembly

Double DIN radio provision

1. Snap the Double DIN brackets to the inside edge of the Double DIN trim plate. (Figure A)
2. Slide the Double DIN radio into the bracket/trim plate assembly and secure the radio to the assembly using the screws supplied with the radio. (Figure B)
3. Locate the factory wiring harness and antenna plug in the dash.
4. Mount the new radio assembly into the dash and reassemble the dash in reverse order of disassembly.

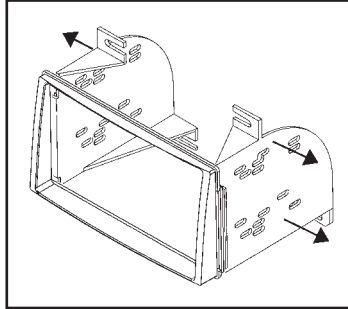

(Figure A)

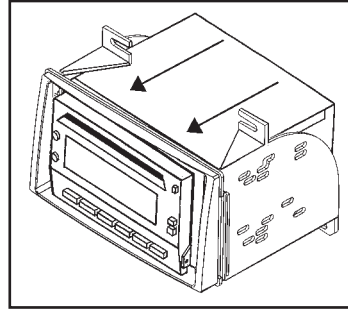

(Figure B)