

APPLICATIONS
See application list inside

Nissan 370Z 2009-up (without navigation) 50-772

KIT FEATURES

- DIN radio provision with pocket
- ISO radio provision with pocket
- Double DIN radio provision
- **Painted matt black to match factory finish**



KIT COMPONENTS

- A) Radio housing
- B) ISO Brackets
- C) ISO Trim plate
- D) Pocket
- E) Double DIN brackets
- F) Double DIN trim plate
- G) Air conditioning module brackets

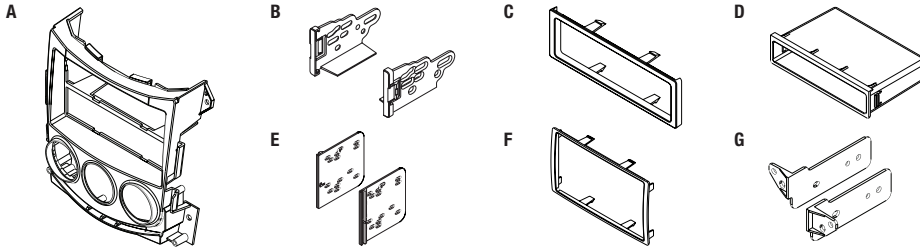

TOOLS REQUIRED

- Panel removal tool
- Small flat blade screwdriver
- Phillips screwdriver
- Socket set

CAUTION: All accessories, switches, and especially air bag indicator lights must be plugged in before reconnecting the battery or cycling the ignition.

NOTE: Refer to the instructions included with the radio.

Table of Contents

Dash Disassembly

- Nissan 370Z 2009-up (without navigation)2-3

Kit Assembly

- Kit preparation 3
- DIN radio provision with pocket..... 4
- ISO DIN radio provision with pocket..... 5
- Double DIN radio provision 6

Nissan 370Z 2009-up (without navigation)

1. For automatic shift models:
Unclip and remove the small shifter trim panel including the hazard switch. (Figure A)

Unclip and remove the large shifter trim panel. (Figure B)

For manual shift models:
The shift trim is one piece, unsnap carefully and set aside.

2. Remove (1) Phillips screws from each side panel on the center console at the bottom of the radio panel then unclip and remove the panels. (Figure B)

Continued on next page

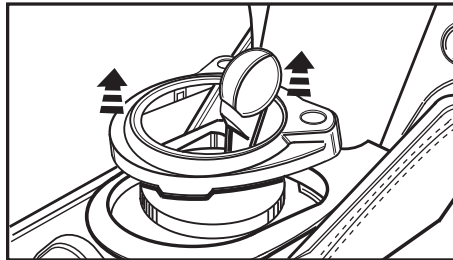

(Figure A)

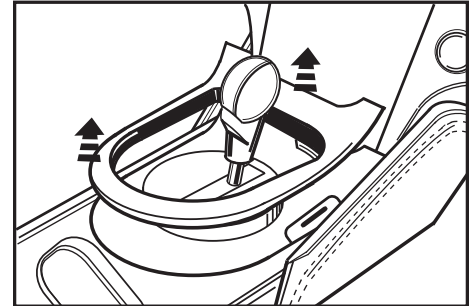

(Figure B)

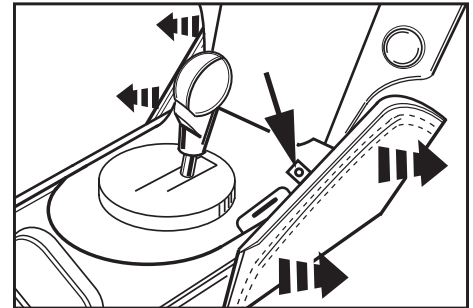

(Figure C)

Dash Disassembly

Kit Assembly

Nissan 370Z 2009-up (without navigation)

Kit Preparation

3. Remove (2) Phillips screws from the bottom of the large trim panel including the A/C vents and pocket assembly then unclip and remove the panel. (Figure D)
4. Remove (4) Phillips screws securing the factory radio and A/C control. (Figure E)
5. Remove (5) Phillips screws securing the A/C control to the factory radio trim panel.
6. Remove (2) Phillips screws securing the A/C module to the factory radio bracket assembly.
Continue to kit preparation

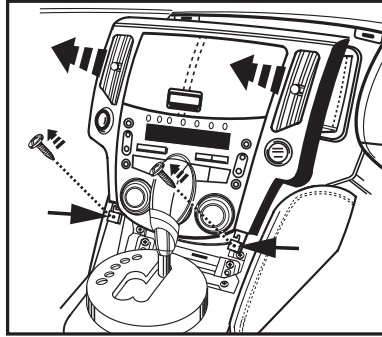

(Figure D)

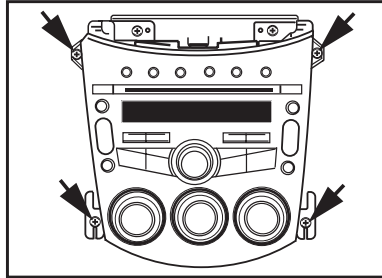

(Figure E)

1. Secure the A/C control into the radio housing using the factory hardware. (Figure A)
2. Attach the included brackets to the A/C module then secure it into the dash using the factory hardware. (Figure B)
Continue to kit assembly

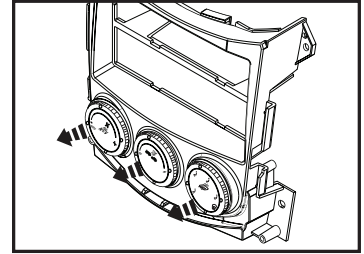

(Figure A)

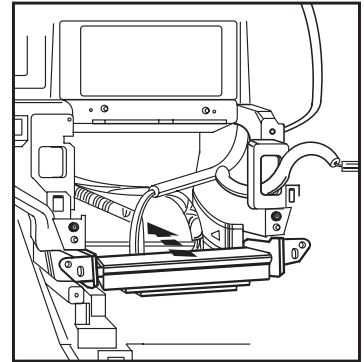

(Figure B)

Kit Assembly

DIN radio provision with pocket

1. Remove the metal sleeve from the aftermarket radio. Slide the sleeve into the radio housing, and secure by bending the metal locking tabs outward. (Figure A)
2. Snap the pocket into the bottom opening of the radio housing. (Figure B)
3. Slide the radio into the sleeve until it locks in. (Figure C)
4. Locate the factory wiring harness in the dash. Re-connect the negative battery terminal and test the radio for proper operation.
5. Reassemble dash in reverse order of disassembly.

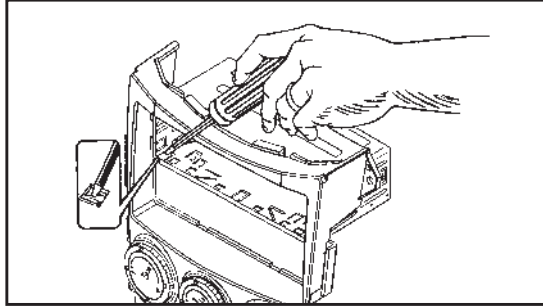

(Figure A)

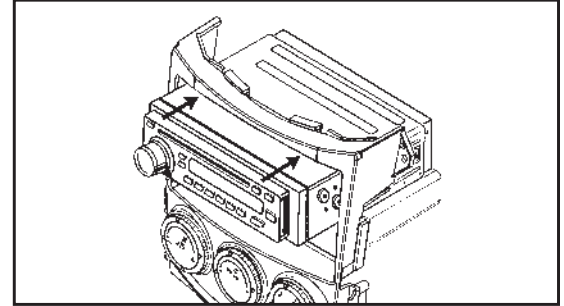

(Figure C)

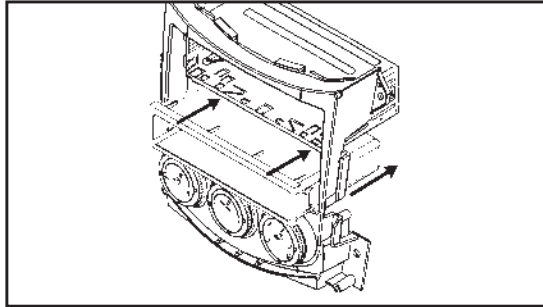

(Figure B)

ISO DIN radio provision with pocket

1. Remove the trim ring from the aftermarket radio. Mount the ISO brackets to the radio with the screws supplied with the radio. (Figure A)
2. Snap the pocket into the bottom opening of the radio housing. (Figure B)
3. Slide the radio into the radio housing until the side clips engage. (Figure C)
4. Snap the trim plate into the radio housing. (Figure C)
5. Locate the factory wiring harness in the dash. Re-connect the negative battery terminal and test the radio for proper operation.
6. Reassemble dash in reverse order of disassembly.

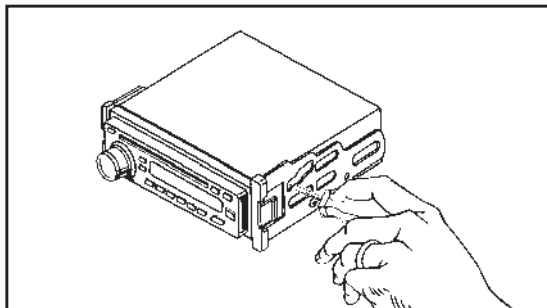

(Figure A)

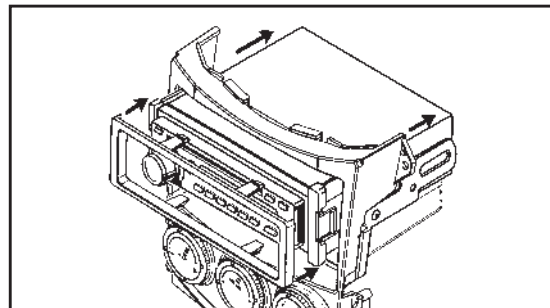

(Figure C)

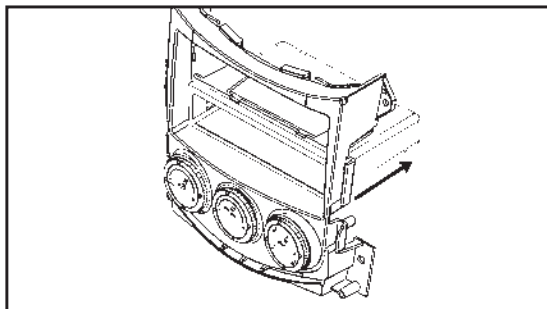

(Figure B)

Kit Assembly

Double DIN radio provision

1. Cut and remove the center bar from the radio housing. (Figure A)
2. Snap the double DIN brackets to the inside edge of the radio housing. (Figure B)
3. Slide the double DIN radio into the bracket/trim plate assembly and secure the radio to the assembly using the screws supplied with the radio. (Figure C)
4. Snap the double DIN trim-plate onto the housing/radio assembly.
5. Locate the factory wiring harness in the dash. Re-connect the negative battery terminal and test the radio for proper operation.
6. Reassemble dash in reverse order of disassembly.

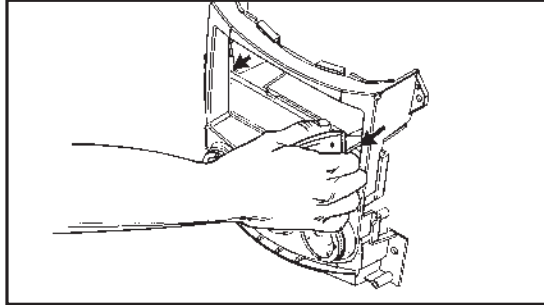

(Figure A)

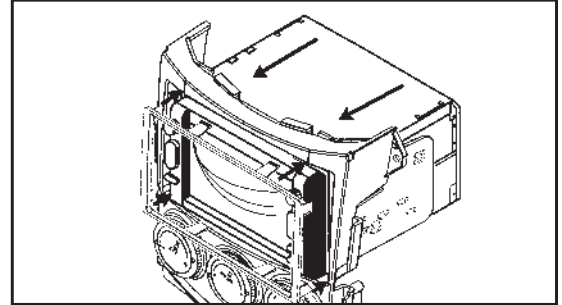

(Figure C)

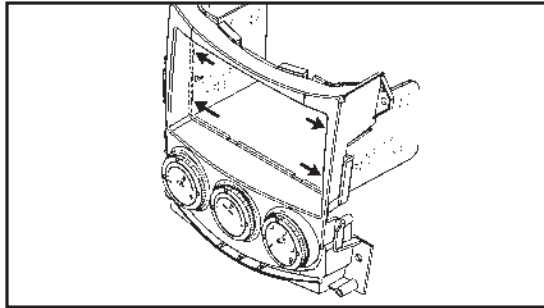

(Figure B)