

Signature



Driven by passion.

WS 6.300

High power woofer

- Woofer 6-1/2" (165 mm)
- Max power 250 W / Nom. power 125 W
- Frequency response 50 Hz - 5 kHz
- Impedance 2 Ω

Die cast aluminium basket - Ultra rigid carbon fiber cone - NBR surround - Long life "Conex" spider - 38 mm (1.5") voice-coil on fiberglass former - Oversized 100 mm x 20 mm magnetic motor - Gold-plated terminal



TECHNICAL SPECIFICATIONS

Component	Woofer	
Max power	250 W	
Nominal power	125 W	
Impedance	2 Ω	
Freq. Response	50 Hz - 5 KHz	
Sensitivity (2,83V/1m)	93,2 dB	
Magnet	Ferrite	
Magnet size Ø x h	100 x 20 mm	3,937 "x 0,787 "
Total driver displacement	0,3 l	0,011 cf
Weight of one component	1,81 kg	2,756 lb
Voice coil Ø	38 mm	1,496"
Voice coil height	17 mm	0,669"
Cone	Carbon fiber	

Unit : mm

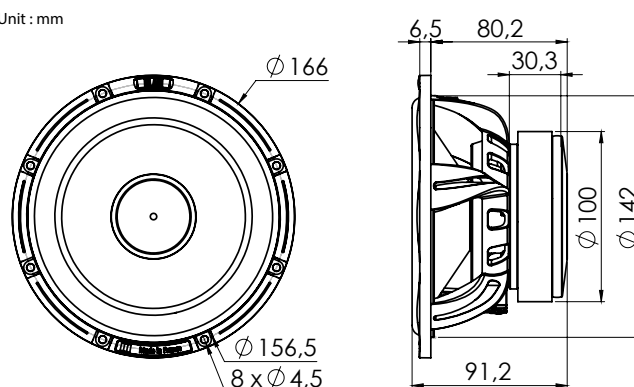

FREQUENCY RESPONSE / IMPEDANCE

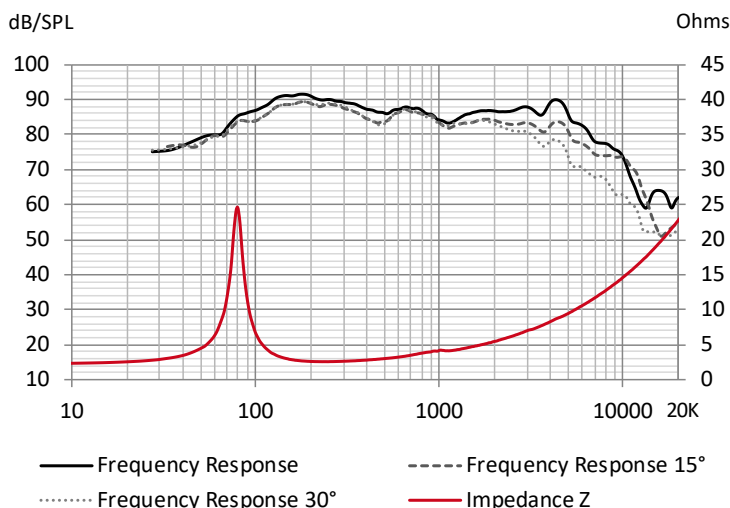

THIELE-SMALL PARAMETERS

effective Ø (d)	128 mm
Sd	128,68 cm ²
Xmax	6 mm
Re	2,1 Ω
Fs	79,43 Hz
Le	117,05 µH @ 1 kHz
Le	285,19 µH @10 kHz
Vas	6,6 L
Mms	14,16 g
Cms	0,000284 m/N
BL	4,59 Tm
Qts	0,74
Qes	0,81
Q0ms	7,86
Sensitivity (dB/W/m)	87,4 dB

Signature



Driven by passion.

MS 3.55

High-efficiency midrange driver

- Extended frequency, can be use as full range
- Frequency Response 200 Hz - 27 KHz

Recommended enclosure

0,3 litres

1,9 litres

Die cast aluminium basket - Ultra rigid carbon fiber cone - NBR surround - Long life « conex » spider - 20 mm Voice Coil, fiber glass former - 55 mm x 10 mm Oversized Magnetic motor - Machined aluminum phase plug - Gold-plated terminal.



TECHNICAL SPECIFICATIONS

Component	Midrange	
Max power	100 W	
Nominal power	25 W	
Impedance	3 Ω	
Freq. Response	200 Hz - 27 KHz	
Sensitivity (2,83V/1m)	88 dB	
Magnet	Ferrite	
Magnet size Ø x h	55 x 10 mm	2,165" x 0,394"
Total driver displacement	0,060 l	0,002 cf
Weight of one component	0,326 kg	0,723 lb
Voice coil Ø	20 mm	0,787"
Voice coil height	6 mm	0,236"
Cone	Carbon fiber	

FREQUENCY RESPONSE / IMPEDANCE

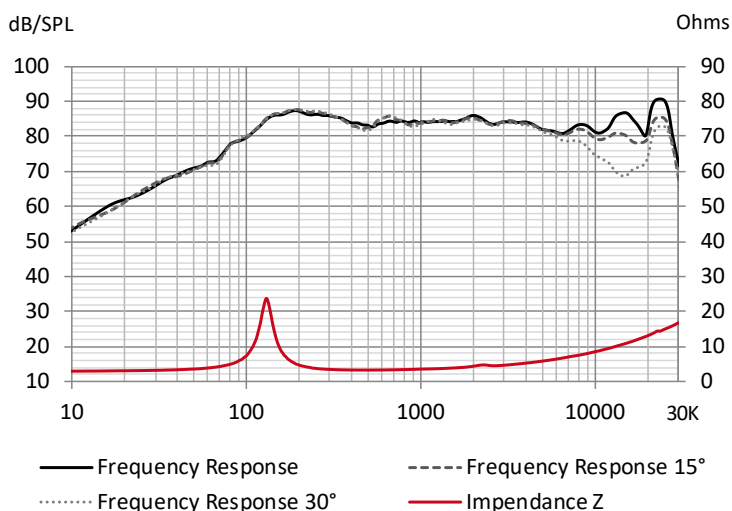

Unit : mm

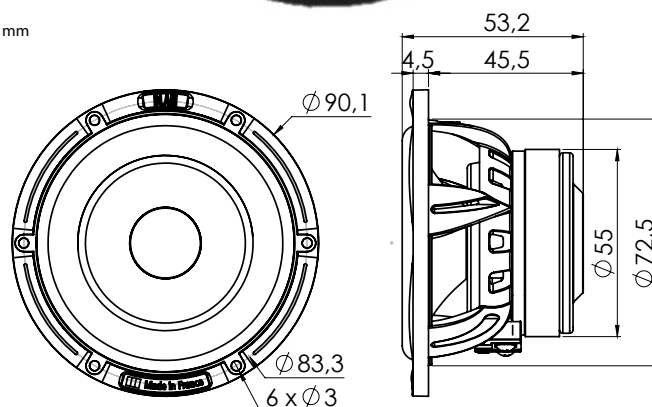

THIELE-SMALL PARAMETERS

effective Ø (d)	61 mm
Sd	29,22 cm ²
Xmax	1 mm
Re	3 Ω
Fs	129,93 Hz
Le	58,18 µH @ 1 kHz
L2	134,68 µH @10 kHz
Vas	0,80 L
Mms	2,24 g
Cms	0,000671 m/N
BL	2,40 Tm
Qts	0,89
Qes	1,04
Qms	6,41
Sensitivity (dB/W/m)	83,8 dB

RECOMMENDED ENCLOSURES

Internal volume Vb	Resonance frequency	Qtc	F-3dB	Boost
0,3 L	248	1,713	171 Hz	5,0 dB at 270 Hz
1,9 L	155	1,067	119 Hz	1.6 dB at 207 Hz

contact@blam-audio.fr
www.facebook.com/blamaudio

www.blam-audio.com

Signature



Driven by passion.

TS 20HR

High resolution tweeter

- 5 ohm, Neo magnet
- 20 mm (3/4") textile dome diaphragm
- Compact mounting dimensions
- High efficiency magnet (N38H neodymium)
- Ferrofluid for high power handling



TECHNICAL SPECIFICATIONS

Component	Tweeter	
Max power	100 W	
Nominal power	10 W	
Impedance	5 Ω	
Freq. Response	2,5 KHz - 40 KHz	
Sensitivity (2,83V/1m)	88,3 dB	
Magnet	Neodymium	
Magnet size \varnothing x h	18 x 4 mm	0,709" x 0,157"
Total driver displacement	-	
Weight of one component	0,03 kg	0,066 lb
Voice coil \varnothing	20 mm	0,787"
Voice coil height	1,3 mm	0,051"
Cone	Soft	

Unit : mm

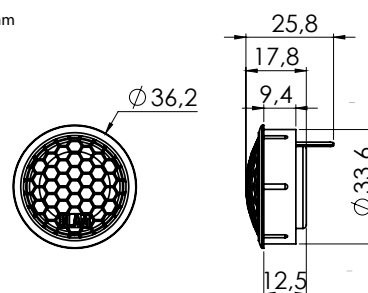

FREQUENCY RESPONSE / IMPEDANCE

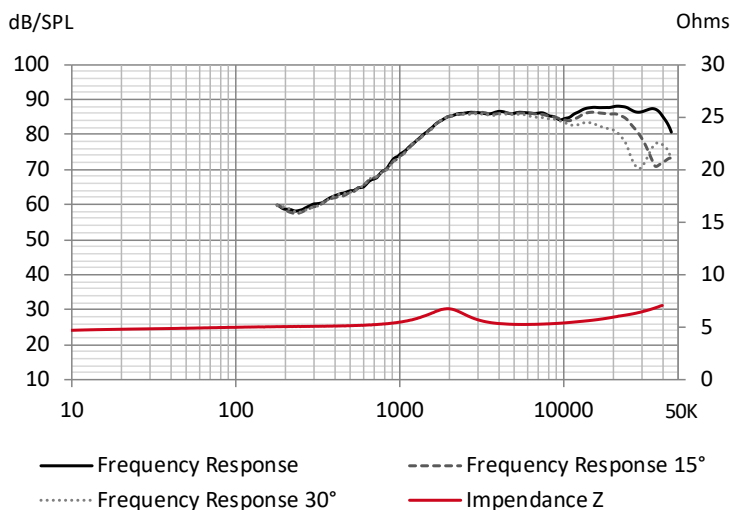

THIELE-SMALL PARAMETERS

effective \varnothing (d)	32 mm
Sd	8,04 cm ²
Xmax	-
Re	5 Ω
Fs	1972,85Hz
Le	-
L2	-
Vas	-
Mms	-
Cms	-
BL	-
Qts	-
Qes	-
Qms	-
Sensitivity (dB/W/m)	86,3 dB

contact@blam-audio.fr
www.facebook.com/blamaudio

www.blam-audio.com