

LIVE



Driven by passion.

LSP 20

Subwoofer

200 mm (8") subwoofer
Dual voice coil

- Max. power 500 W / Nominal Power 250 W
- Frequency response 35 Hz - 500 Hz
- Sensitivity 87 dB
- Impedance 4 Ω (2 x 2 Ω)

Steel basket - Injected polypropylene cone - Foam surround - Long life "conex" damper - 50 mm (2") dual voice coil on aluminium former - Dual 120 mm x 20 mm (4.7" x 0.8") motor assembly - Extended T yoke.



Unit : mm

TECHNICAL SPECIFICATIONS

Component	Subwoofer	
Max power	500 W	
Nominal power	250 W	
Impedance	2 x 2 Ω	
Freq. Response	35 - 500 Hz	
Sensitivity (2,83V/1m)	87 dB	
Magnet	Ferrite	
Magnet size Ø x h	2 x 120 x 20 mm	4.724" x 0.787"
Total driver displacement	1 l	0.035 cf
Weight of one component	3.9 kg	8.598 lb
Voice coil Ø	50 mm	1.969"
Voice coil height	33.4 mm	1.315"
Cone	Textured PP	

FREQUENCY RESPONSE / IMPEDANCE

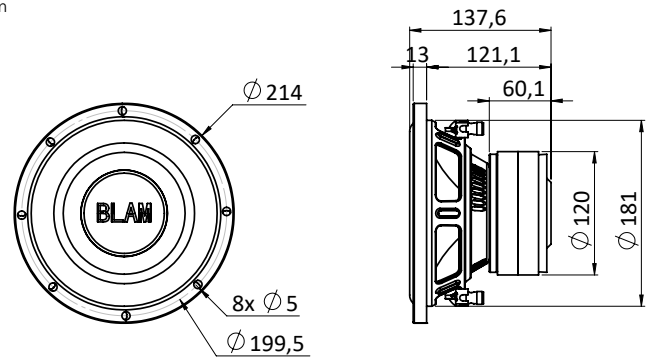
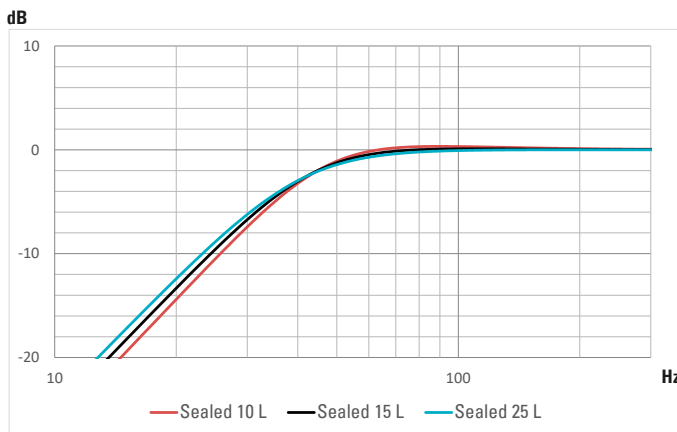

THIELE-SMALL PARAMETERS

effective Ø (d)	165 mm
Sd	213.82 cm ²
Xmax	13 mm
Re	1.1 Ω
Fs	35.56 Hz
Le	256.06 µH @ 1 kHz
Le	717.32 µH @10 kHz
Vas	7.21 L
Mms	178.39 g
Cms	0.000112 m/N
BL	7.96 Tm
Qts	0.64
Qes	0.71
Qms	6.54
Sensitivity (dB/W/m)	78.05 dB

RECOMMENDED ENCLOSURES

Internal volume Vb	F-3dB	Boost
10 L	41 Hz	0.3 dB at 90 Hz
15 L	41 Hz	0.1 dB at 110 Hz
25 L	40 Hz	no boost

contact@blam-audio.fr
www.facebook.com/blamaudio

www.blam-audio.com