

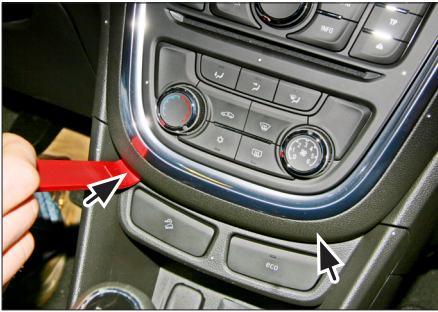

1. Vauxhall Mokka OEM dashboard

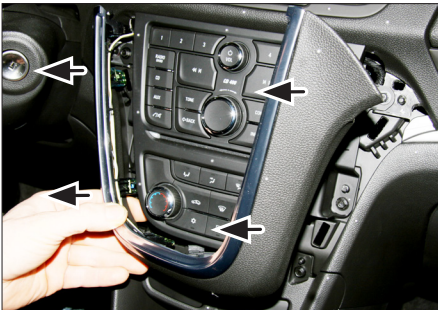

2. Unclip panel carefully (see arrows)



3. Pull panel towards your direction carefully

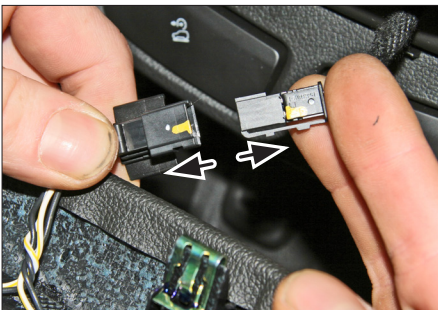

4. Unplug cable at the panel backside



5. Remove screws of OEM head unit

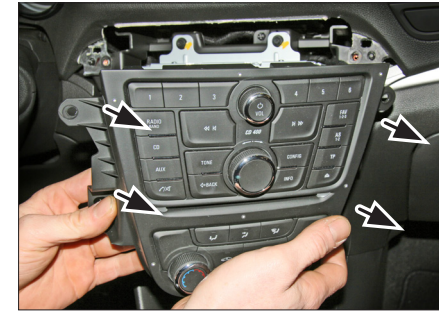

6. Pull OEM control unit towards your direction



7. Remove two plugs

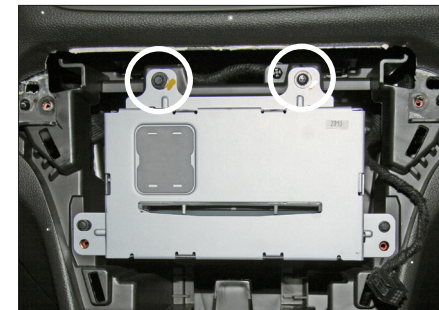

8. Remove two screws on top
Pull out OEM head towards your direction

Unplug all cables of OEM head unit - and remove it

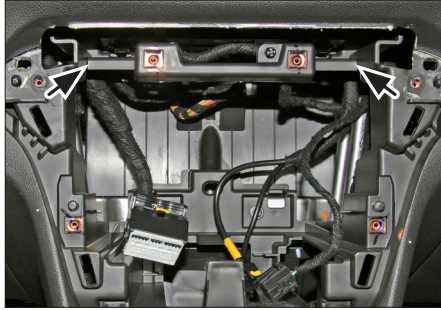

9. Cut away „bridge“ in order to clear space for double DIN head unit

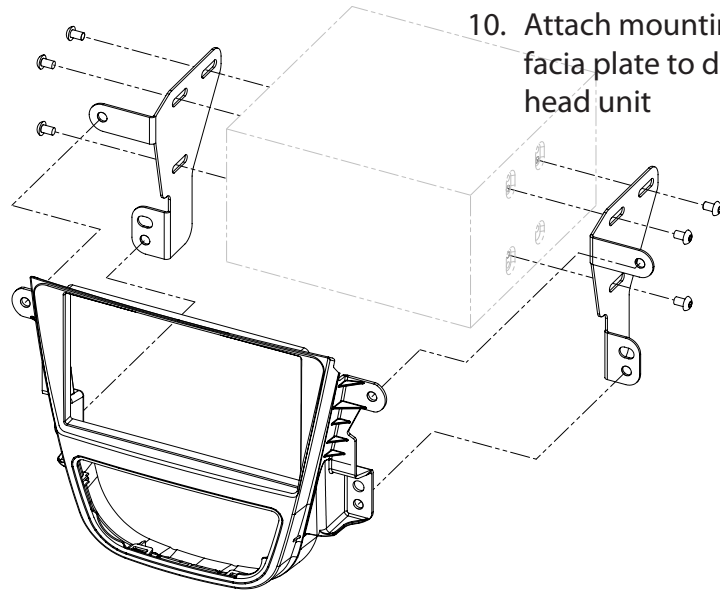

10. Attach mounting frames and fascia plate to double DIN head unit



11. Connect all required circuit points

Fix double DIN head unit on dashboard

Reinstall everything in reverse order to finish installation