



50-647

Subaru Legacy/Outback (with NAV) 2010-2012

KIT FEATURES

- ISO DDIN radio provision
- Painted silver to match the factory finish
- Includes a pocket to replace the factory radio controls

KIT COMPONENTS

- A) Radio trim panel • B) Radio brackets • C) Pocket • D) (4) #8 x 3/8" Phillips screws • E) (4) Panel clips

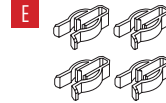
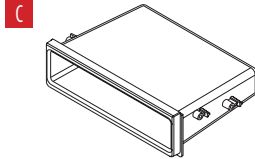
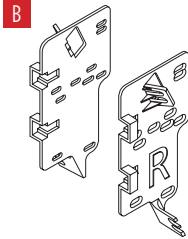
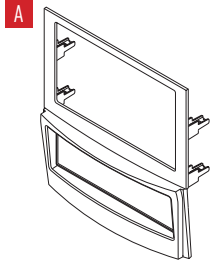

TABLE OF CONTENTS

Dash Disassembly	2
Kit Assembly	3

Attention! Let the vehicle sit with the key out of the ignition for a few minutes before removing the factory radio. When testing the aftermarket equipment, ensure that all factory equipment is connected before cycling the key to ignition.

DASH DISASSEMBLY

1. Unclip and remove the a/c vent trim panel surrounding the radio. (Figure A)
2. Remove (6) Phillips screws securing the radio/display. Slide the radio/display out, then unplug and remove the radio/display.

Note: The antenna cable is connected down lower by the floorboard.

Continue to Kit Assembly

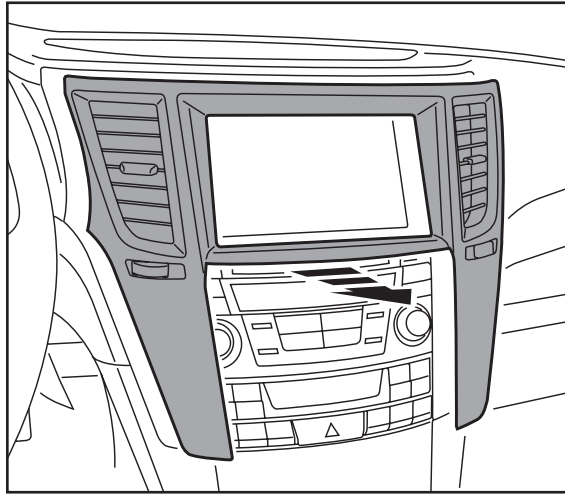

(Figure A)

KIT ASSEMBLY

1. Secure the *radio brackets* to the radio using the screws supplied with the radio. (Figure A)
2. Secure the *pocket* to the bottom portion of the *radio brackets* using the (4) #8 x 3/8" Phillips screws provided. (Figure B)
3. Locate the factory wiring harness and antenna connector in the dash and complete all necessary connections to the radio.

Note: The amplifier turn-on wire must be tapped into the factory radio harness. Locate pin-23, a **Pink** wire, in the 24-pin harness.

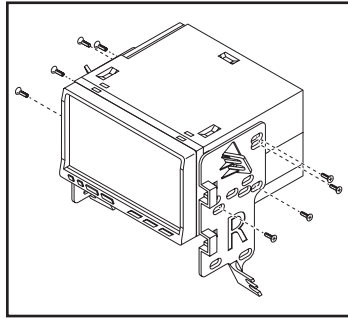

(Figure A)

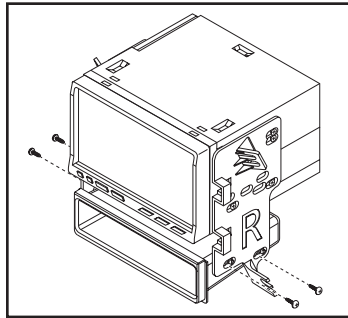

(Figure B)

4. Secure the radio assembly to the dash using the factory screws.
5. Attach the (4) *panel clips* provided onto the *radio trim panel*, then clip the *radio trim panel* onto the radio assembly. (Figure C)
6. Reassemble the dash in reverse order of disassembly to complete the installation.

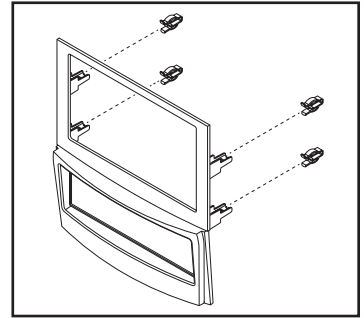

(Figure C)