

27-553

Mercedes NTG5 camera input interface



9: Rear video -	1: Front video -
10: Rear video +	2: Front video +
11: n/c	3: n/c
12: n/c	4: n/c
13: n/c	5: Reverse trigger in
14: Ground	6: n/c
15: +12V output power supply for camera	7: n/c
16: +12V constant output	8: +12V output accessory

Installation:

Make sure the key is out and the vehicle is off. Set the switches on the interface before connecting.

Remove the original head unit.

Disconnect the original LVDS connector from the head unit and connect it to the interface.

Connect the new LVDS lead from the interface to the original head unit.

Disconnect the connector at the head unit and fit the supplied T lead in line.

Connect the cameras to the camera input harness, this harness also supplies optional power outputs to the camera. Cars with manual gears may need the reverse trigger wire to be connected.

Test the interface, then refit the head unit.

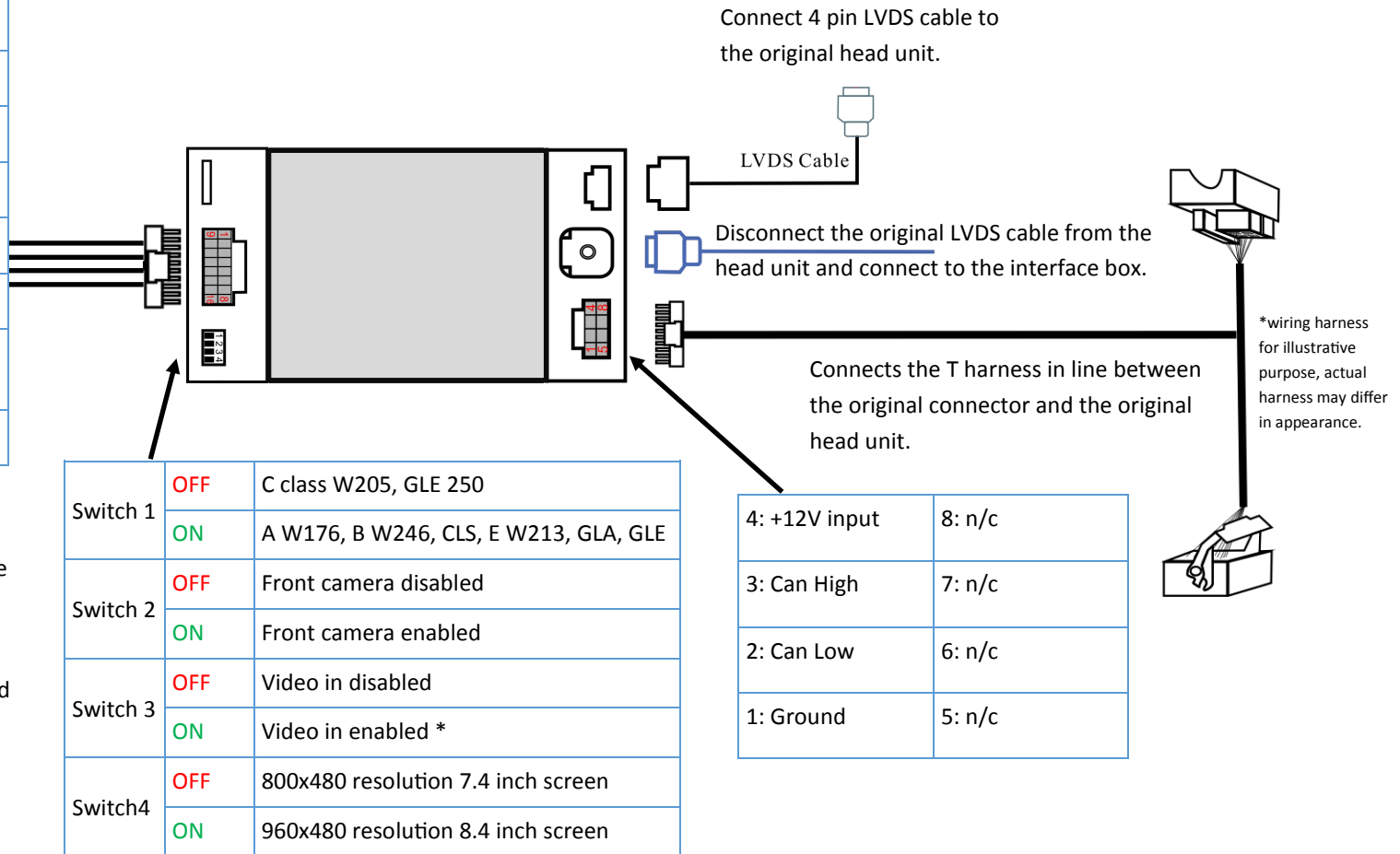

The switches need to be set before the interface is powered. If the switches need to be changed the interface will need to be disconnected from the power to reset.

*Video in is activated by pressing and holding the "return" button on the steering wheel.